

Test: Primary 5 Science (Term 4) - RGPS

Points: 60 points

Name: _____

Score: _____

Date: _____

Signature: _____

Select multiple choice answers with a cross or tick:

Only select one answer

Can select multiple answers

Question 1 of 56

Primary 5 Science (Term 4) 2 pts

For each question, four options are given. One of them is the correct answer. (25 x 2 marks)

The diagram below shows a process in the human reproduction system.

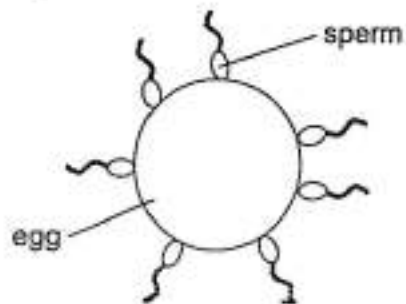

Which one of the following statements about the process of human reproduction is correct?

- A) One egg is fertilised by many sperms.
- B) Pollination occurs before the fertilisation of the egg.
- C) The foetus will develop in the womb for nine months.
- D) The male reproductive cell will fuse with the female reproductive cell in the womb.

The table below shows some physical characteristics of Mr and Mrs Ben and their four children. A tick (✓) shows the presence of the characteristics.

	Short hair	Curly hair	Dimples	Attached earlobes
Mr Ben	✓	✓		✓
Mrs Ben			✓	
Alex	✓			
Billy	✓	✓		✓
Cindy		✓	✓	
Elly		✓	✓	

Based on the information above, which of the following statement(s) is/are definitely correct?

- A Cindy and Elly are a pair of twins.
- B Billy and Alex inherited the short hair from Mr Ben.
- C Billy did not inherit any physical characteristics from Mrs Ben.
- D Cindy and Elly each inherited more than two physical characteristics from Mrs Ben.

-
- A) C only
 - B) A and B only
 - C) B and C only
 - D) A, C and D only

The cycle below show the stages of the growth of a plant.

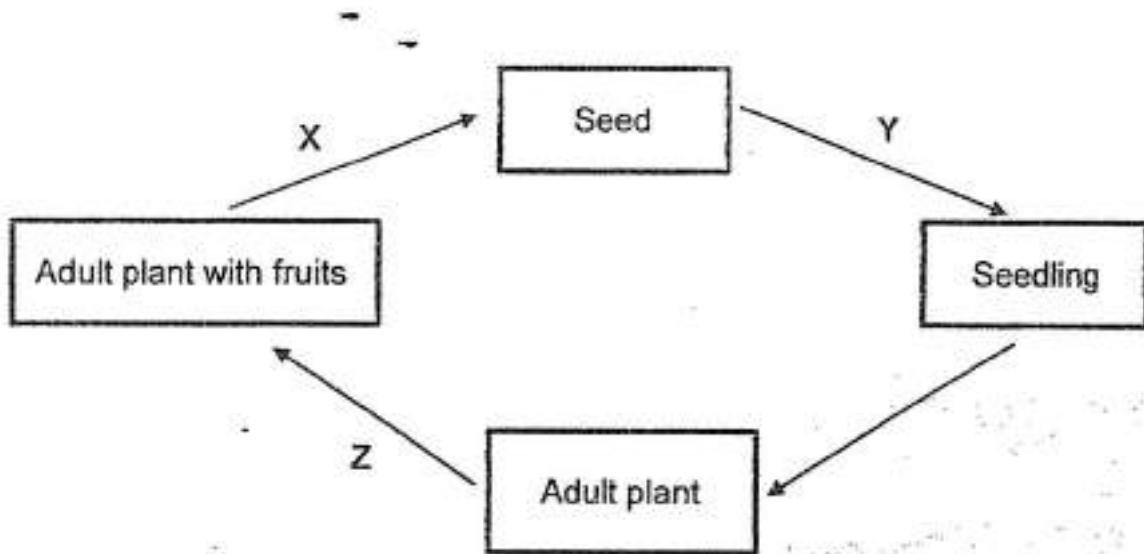

Which of the following represents the stages correctly?

- A)

X	Y	Z
Dispersal	Germination	Fertilisation
- B)

X	Y	Z
Fertilisation	Dispersal	Dispersal
- C)

X	Y	Z
Germination	Fertilisation	Dispersal
- D)

X	Y	Z
Germination	Dispersal	Fertilisation

The chart below shows classification of some living things.

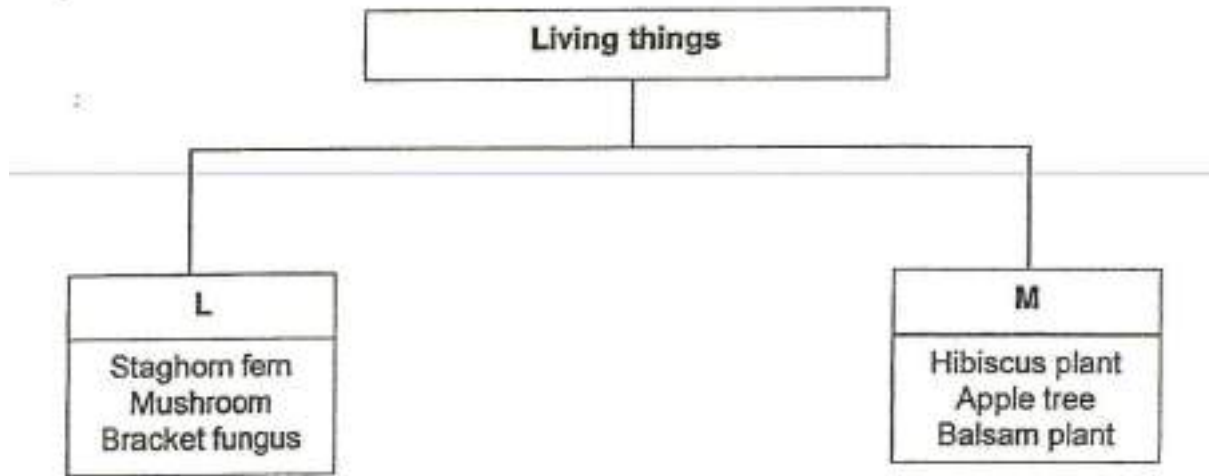

Which of the following is the most suitable headings for L and M?

- A)

L	M
Inedible	Edible
- B)

L	M
Non-flowering plants	Flowering plants
- C)

L	M
Non-green plants	Green plants
- D)

L	M
Reproduce from spores	Reproduce from seeds

Study the diagram below.

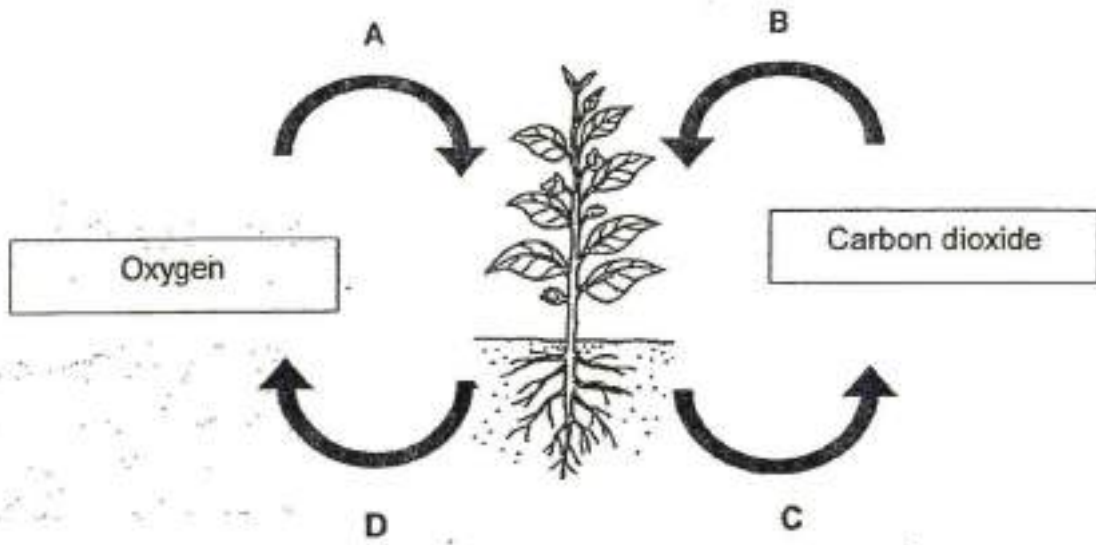

Which pair of arrows shows the exchange of gases during respiration correctly?

- A) A and B
- B) A and C
- C) A and D
- D) C and D

Study the flow chart about different parts P, Q, R and S in human digestive system below.

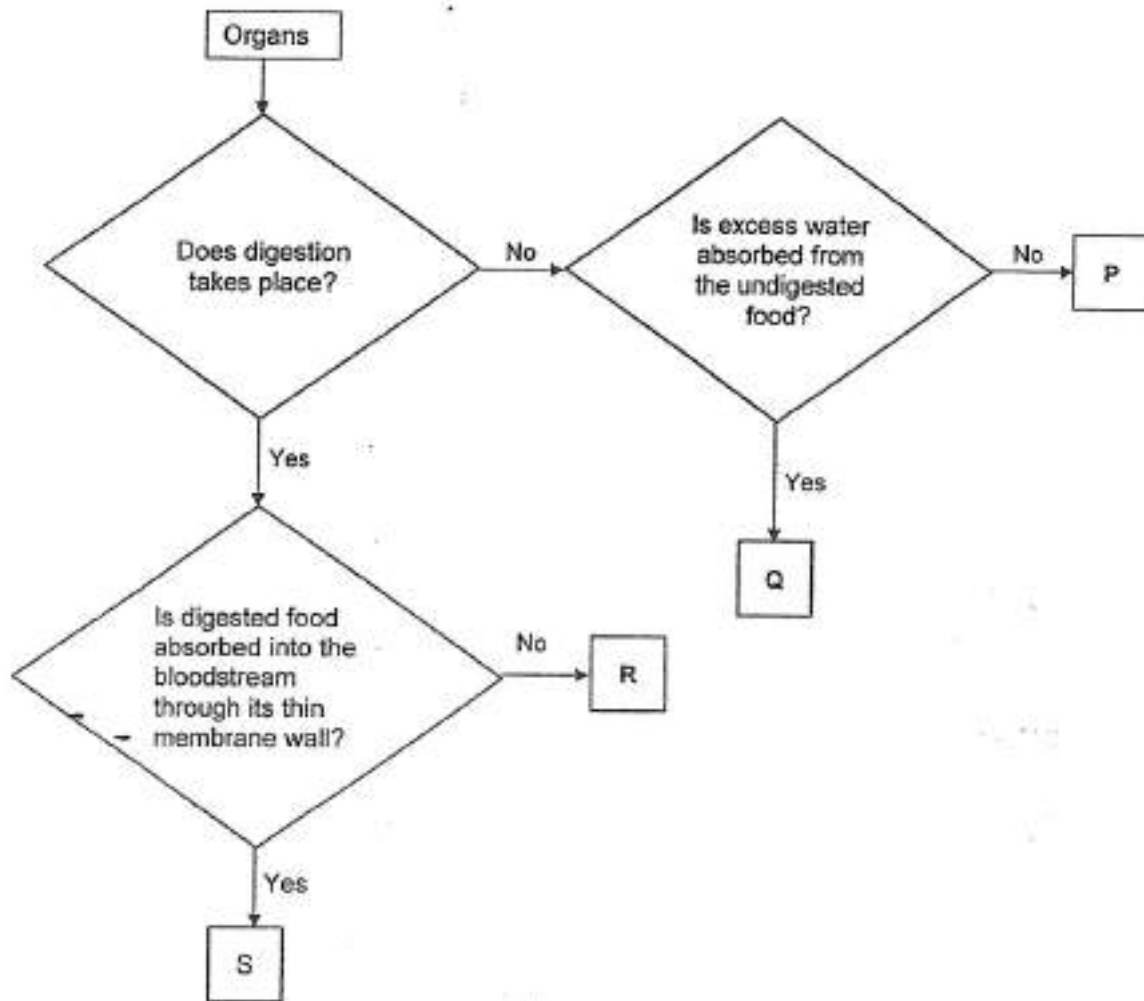

Which of the following best represents P, Q, R and S respectively?

- A)

P	Q	R	S
Anus	Large intestine	Mouth	Small intestine
- B)

P	Q	R	S
Gullet	Mouth	Small intestine	Large intestine
- C)

P	Q	R	S
Mouth	Small intestine	Stomach	Small intestine
- D)

P	Q	R	S
Large intestine	Small intestine	Stomach	Mouth

The experimental set-up below was placed beside an open window during a sunny and bright day.

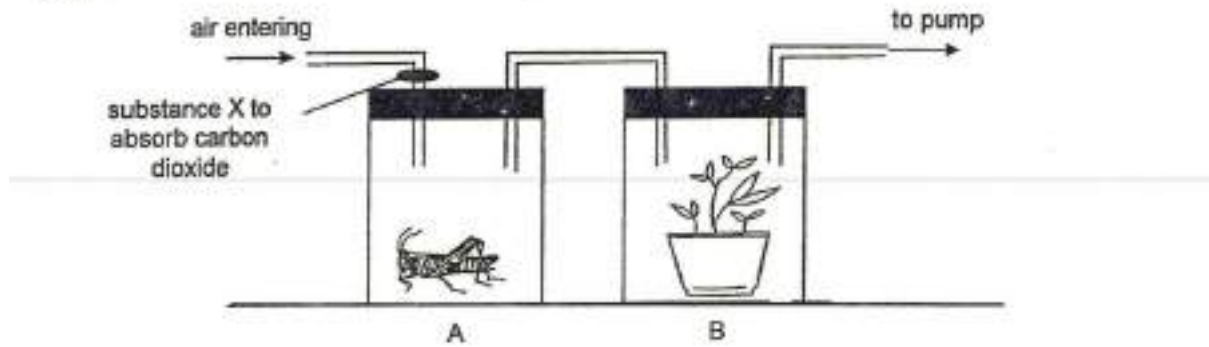

Which of the following pairs shows the gases that enter and leave container B?

- A)

Entering	Leaving
Oxygen, carbon dioxide	Oxygen, water vapour
- B)

Entering	Leaving
Oxygen, water vapour	Oxygen, water vapour
- C)

Entering	Leaving
Oxygen, carbon dioxide, water vapour	Oxygen, carbon dioxide, water vapour
- D)

Entering	Leaving
Oxygen, carbon dioxide, water vapour	Oxygen, water vapour

Set-up X shows how sand is separated from water using filter paper. The filter paper only allows some substances to pass through it.

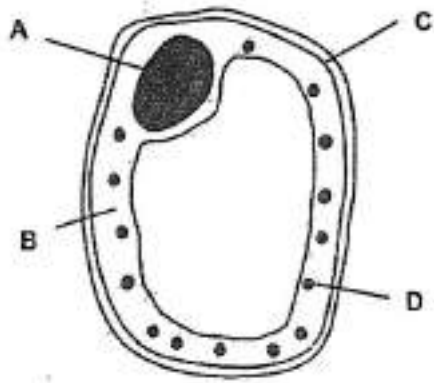

Plant cell

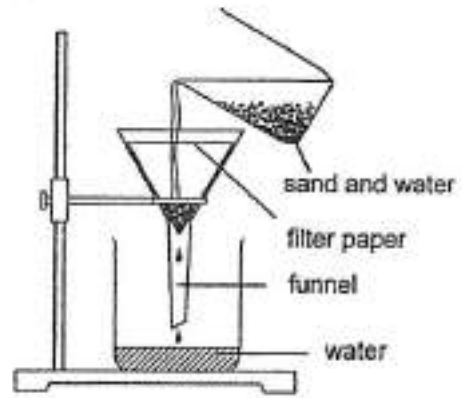

Set-up X

Which part of the plant cell has the same function as the filter paper in set-up X?

- A) A
- B) B
- C) C
- D) D

The diagram below shows the human respiratory system with parts labelled A and B.

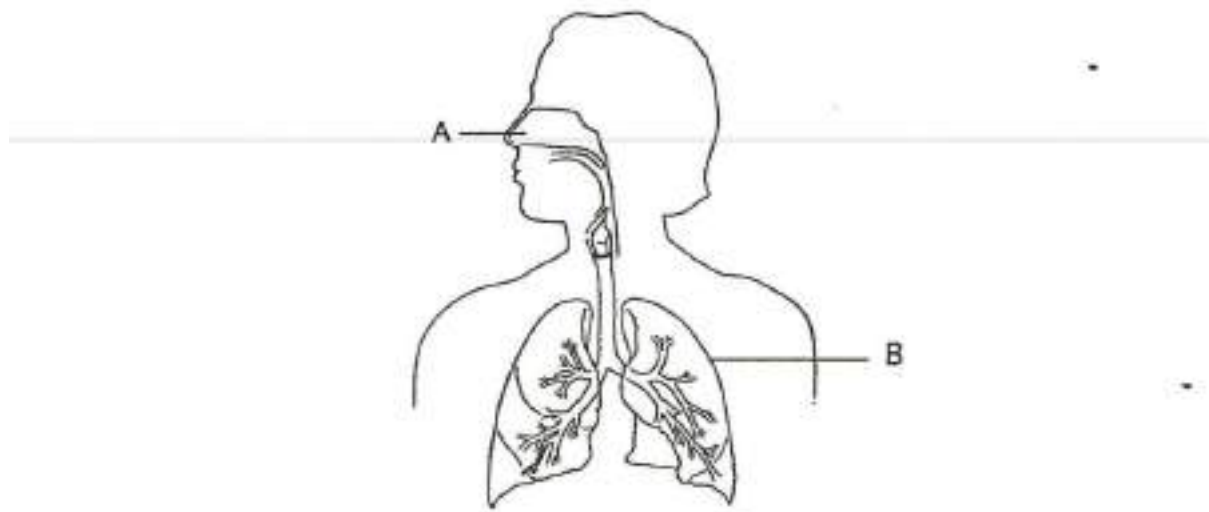

Which one of the following correctly states the functions of A and B during breathing?

- A)

A	B
Controls the types of gases that enter the lungs	Controls the rate of breathing
- B)

A	B
Enables us to detect smell	Prevents the ribcage from collapsing
- C)

A	B
Filters the air before it enters the lungs	Takes in oxygen and remove carbon dioxide
- D)

A	B
Leads air in and out of the respiratory system	Makes the chest cavity air-tight

The diagram below shows how blood flows through the blood vessels from P to Q.

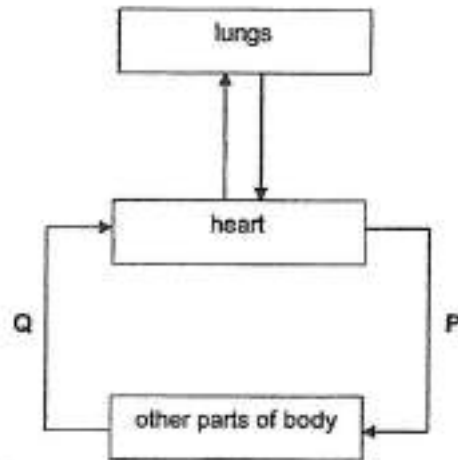

Which of the following best describe the differences between the blood at blood vessels P and Q?

	Blood at P	Blood at Q
A	more oxygen	less oxygen
B	less carbon dioxide	more carbon dioxide
C	less waste materials	more waste materials
D	more digested food	less digested food

- A) A and C only
 B) B and D only
 C) A, B and C only
 D) A, B, C and D

Mary took plant X from the garden and placed in a container filled with water as shown below.

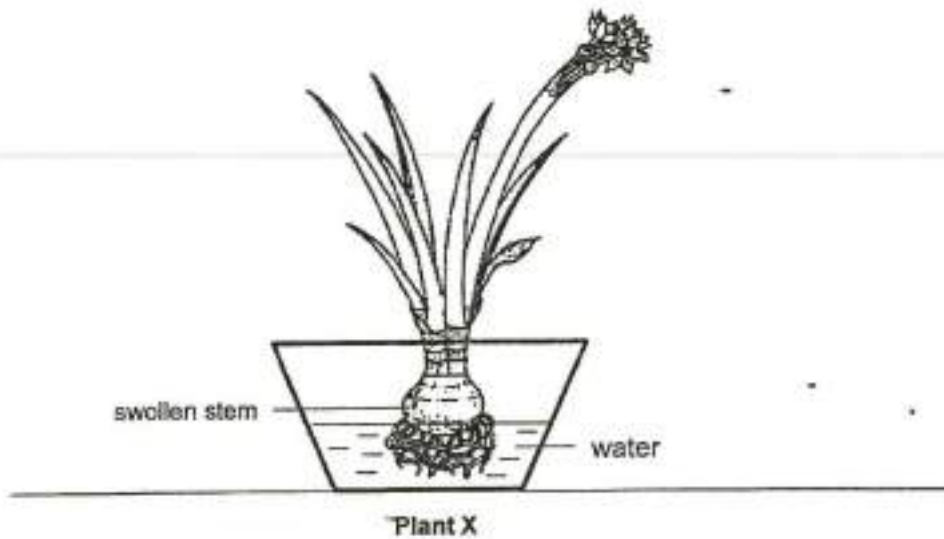

Mary noticed that plant X in her garden grew more healthily but plant X left in the living room withered in a month.

Which of the following is/are the reason(s) for her observation?

- A There was insufficient mineral salts present in the water to be absorbed by the roots of the plant X.
- B There was insufficient light present in the room for the leaves of the plant to make food.
- C The stem of plant X became swollen and could not transport water from the roots to the leaves.

- A) C only
- B) A and B only
- C) A and C only
- D) A, B and C

Peter placed a celery stalk as shown in the picture below. The two glasses had different coloured water, one red and the other blue. After half an hour, he cut across the stalks at positions X, Y and Z, as shown in the diagram below.

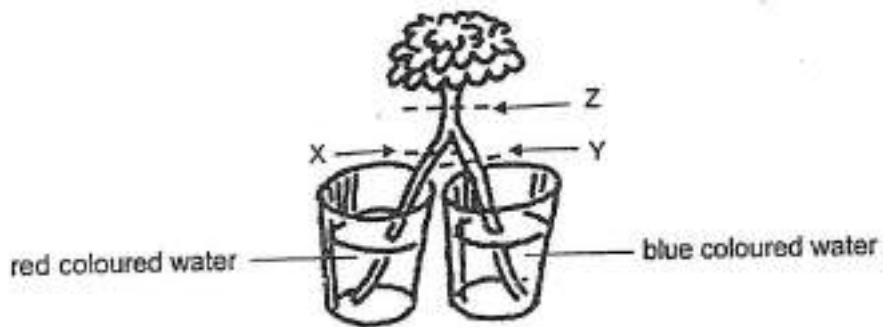

He noticed that the cross-sections cut at X, Y and Z had different coloured dots.



Cross-section of celery stalk

Which of the following shows the possible colour dots observed at parts X, Y and Z of the stem?

- A)

X	Y	Z
All red	All blue	Some red and some blue
- B)

X	Y	Z
All blue	All red	All purple
- C)

X	Y	Z
All purple	All purple	Some red and some blue
- D)

X	Y	Z
All red	All blue	All purple

The graph below shows the melting point and boiling point of Substance A.

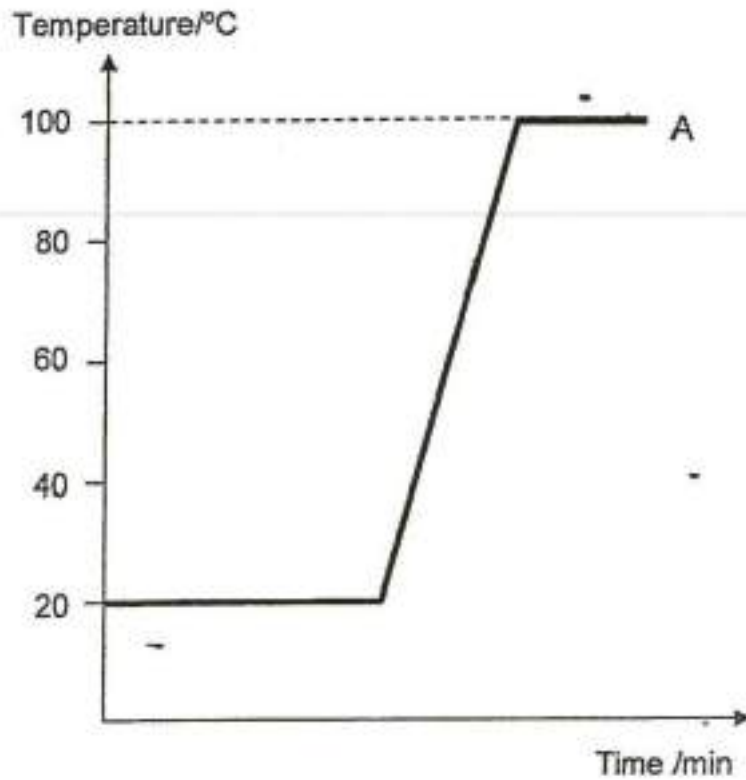

Which one of the following statements about the graph above is not correct?

- A) Substance A is a solid at 10°C.
- B) Substance A is a liquid at 80°C.
- C) The melting point of substance A is 0°C.
- D) The boiling point of substance A is 100°C.

Siti left a block of ice in a beaker on an electronic weighing scale in the kitchen as shown below.

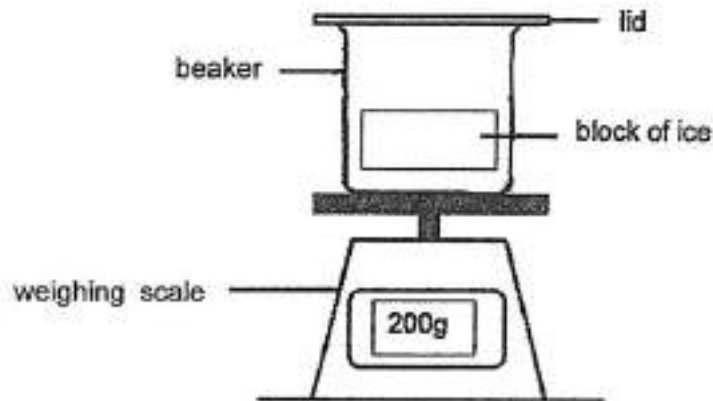

Which of the following statement(s) is/are the most likely observation(s) when the block of ice was left on the weighing scale for five minutes?

- A Water droplets are formed on the underside of the lid.
- B Water droplets are formed on the outside of the beaker.
- C The reading in the weighing scale shows more than 200g.

-
- A) A only
 - B) B only
 - C) B and C only
 - D) A, B and C

When object U is placed in front of a light source, Peter observed a circular shadow formed on the screen.

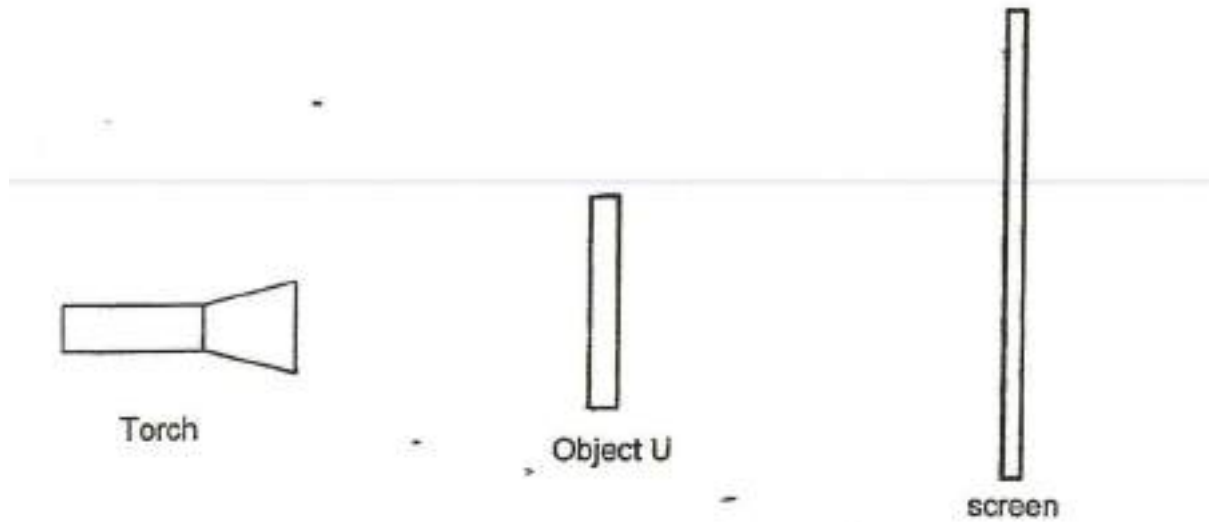

Which one of the following actions will have a bigger shadow be cast on the screen?

- A) Move the torch nearer to object U
- B) Move the screen nearer to object U
- C) Move the torch further from object U
- D) Move object U further from the torch

Ali cut out a circular shape from a wooden block and a triangular shape from a clear plastic block as shown below.

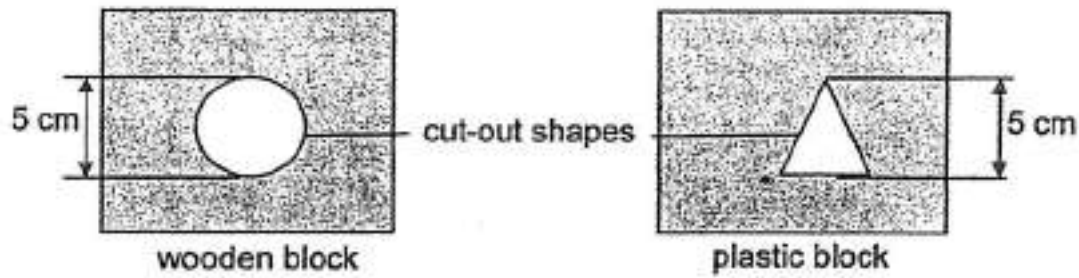

He glued the two blocks together and a lamp with blue light was brought near the two blocks which were glued together as shown in the diagram below.

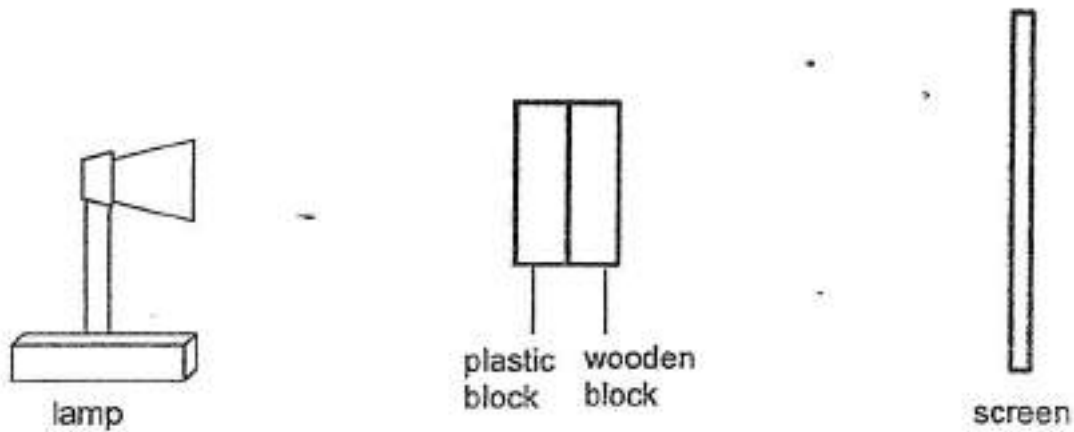

Which one of the following is most likely to be the shadow formed on the screen?

A)

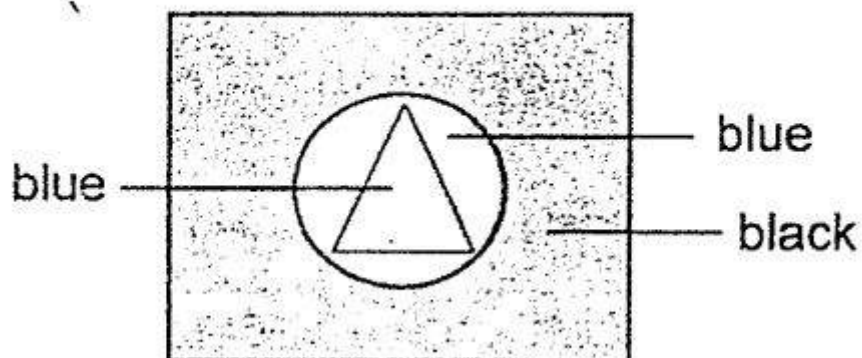

B)

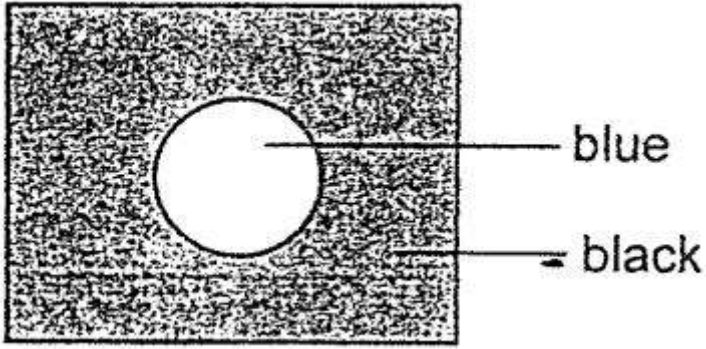

c)

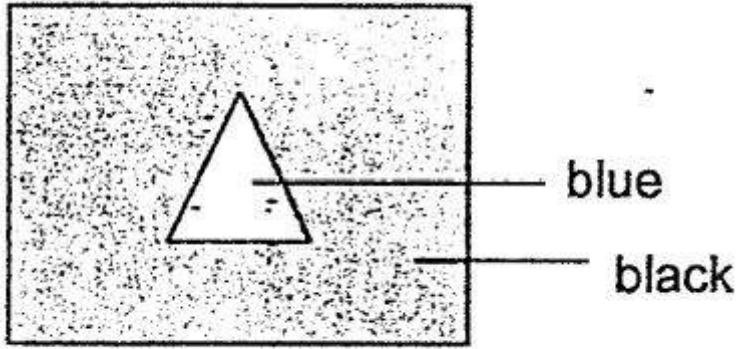

d)

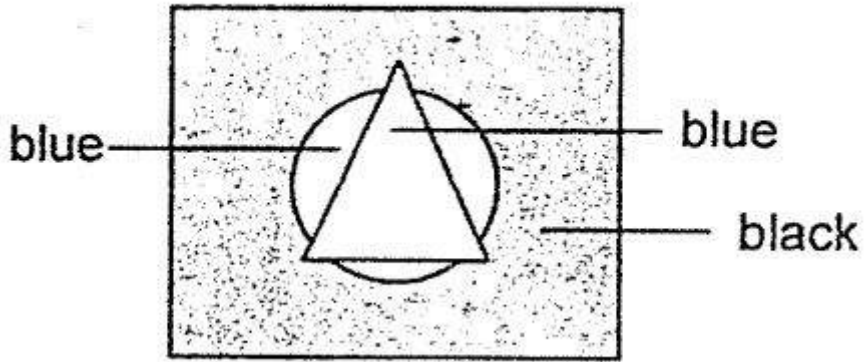

Which one of the following diagram explains why Judy can see the book on the table when the lamp is switched on?

A)

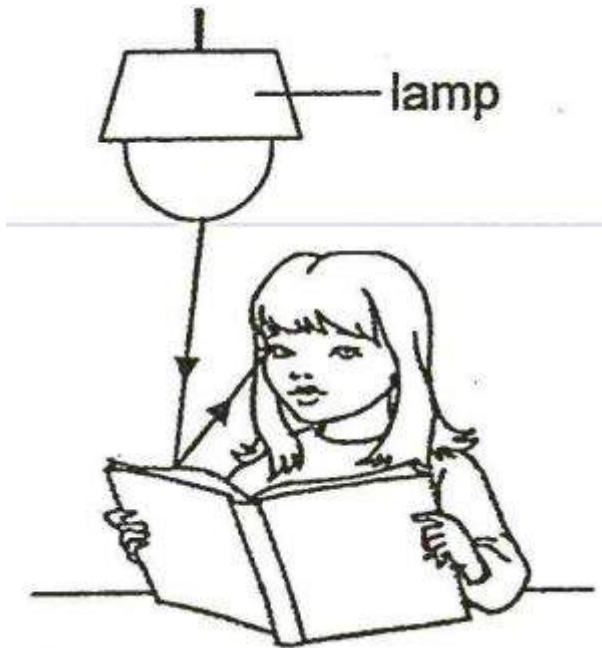

B)

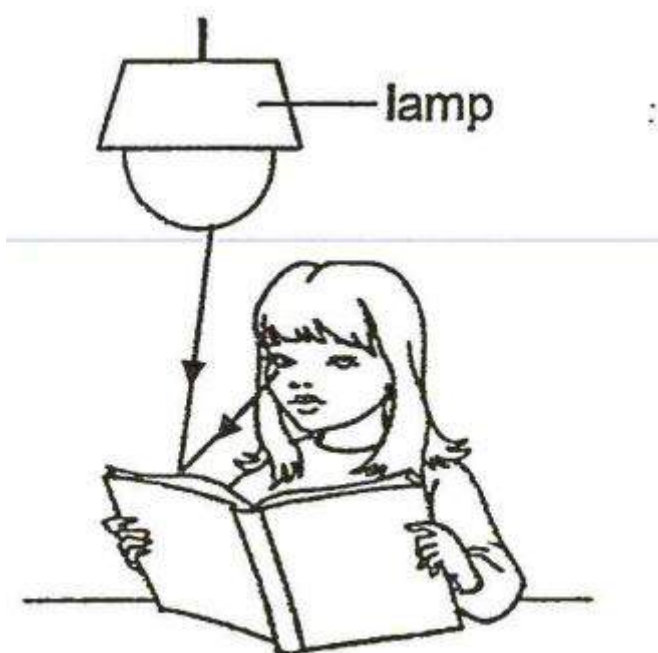

C)

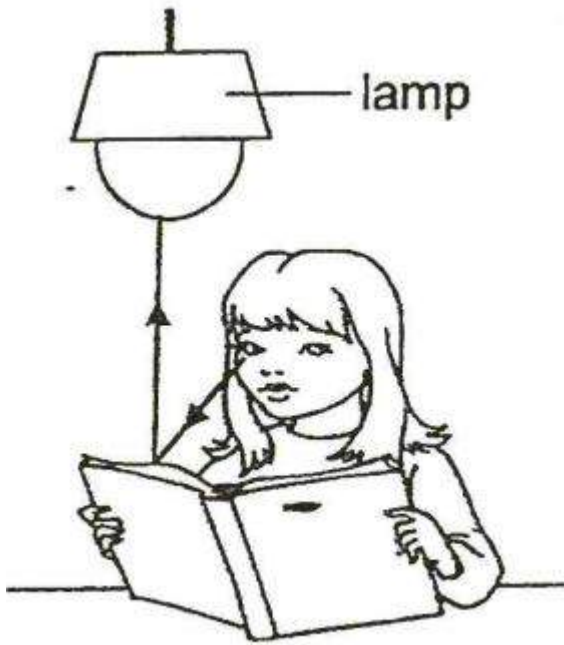

○ D)

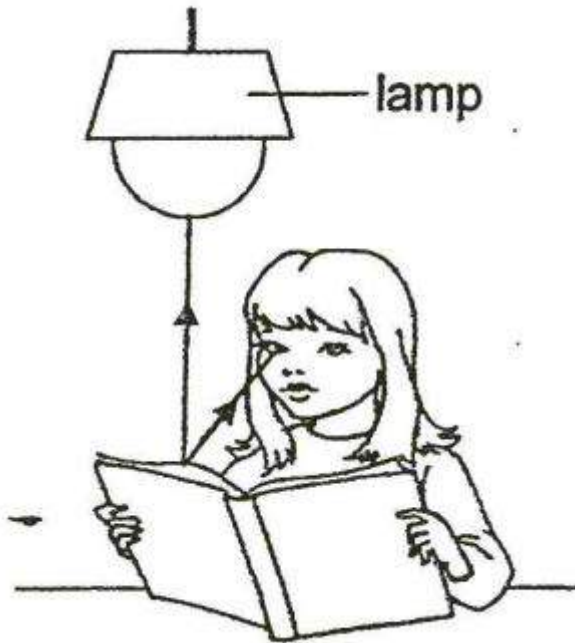

Joseph placed a bowl of ice-cream on the table. After three minutes, he observed his ice-cream melting slowly.

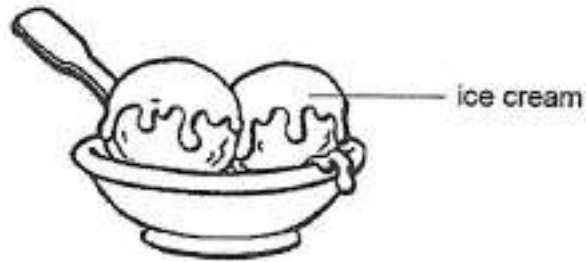

Which of the following correctly shows the transfer of heat between the ice-cream and the surrounding air?

- A)

Surrounding air	Ice-cream
gains heat	gains heat
- B)

Surrounding air	Ice-cream
gains heat	loses heat
- C)

Surrounding air	Ice-cream
loses heat	loses heat
- D)

Surrounding air	Ice-cream
loses heat	gains heat

Winson conducted an experiment using two containers, R and S, made of different materials. He placed an equal amount of water at 5°C in each container as shown below. He used a hot plate to heat the two containers of water to boiling point.

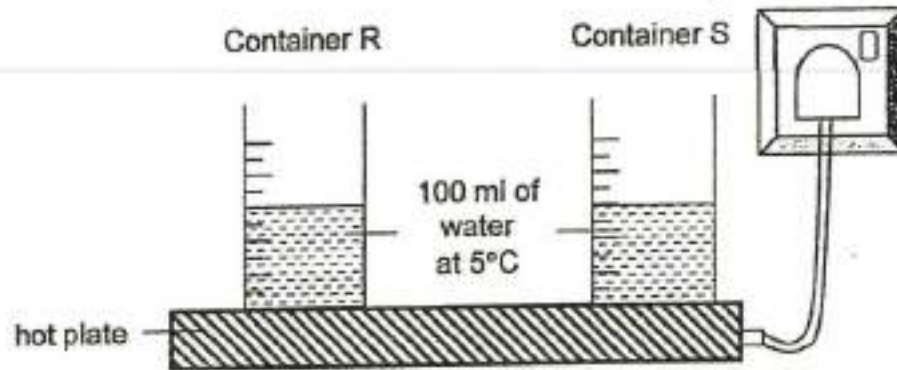

He measured the time taken for the water in each container to reach boiling point and recorded the readings in the table below.

Container	Time Taken (s)
R	70
S	120

Based on the information above, which of the following statement(s) is/are correct?

- A Container R is a poorer conductor of heat than container S
- B The water in container S gained heat from the hot plate more slowly than the water in container R.
- C The water in both containers would have the same amount of heat energy at boiling point.

- A) A only
- B) B only
- C) B and C only
- D) A, B and C only

Mrs Wong set-up an experiment as shown below.

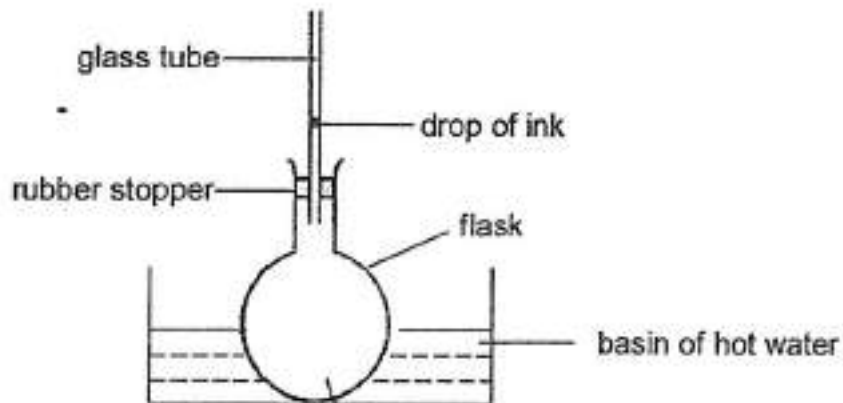

Which of the following statements correctly shows the observation and explanation of what happens to the drop of ink after the flask was placed in the basin of hot water?

- A)
- | Observation | Explanation |
|----------------------------|---|
| The drop of ink will rise. | The air in the flask loses heat to the basin of hot water and expands and pushes the drop of ink upwards. |
- B)
- | Observation | Explanation |
|----------------------------|---|
| The drop of ink will rise. | The air in the flask gains heat from the basin of hot water and expands and pushes the drop of ink upwards. |
- C)
- | Observation | Explanation |
|----------------------------|--|
| The drop of ink will drop. | The air in the glass tube contracts and loses heat to the basin of hot water and pushes the drop of ink downwards. |
- D)
- | Observation | Explanation |
|----------------------------|--|
| The drop of ink will drop. | The air in the flask and glass tube expands and gains heat from the basin of hot water and pushes the drop of ink downwards. |

Mary placed points X and Y of the circuit tester shown below on different points 1, 2, 3, 4 and 5 of a circuit card. She observed if the bulb lit up and recorded her observations.

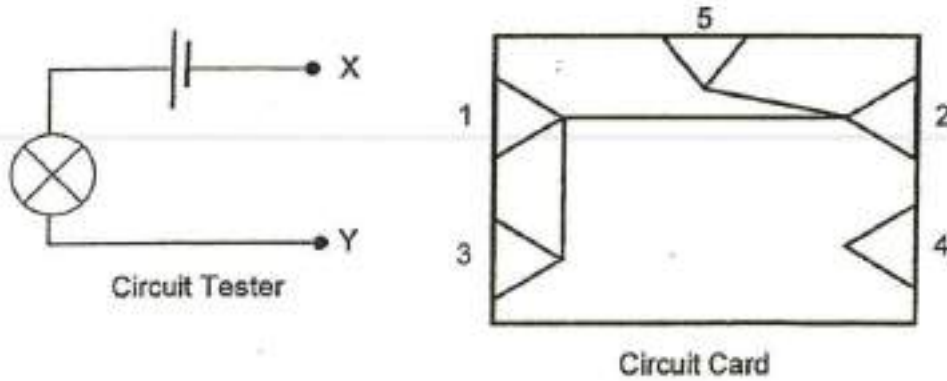

	Points in contact with circuit tester	Bulb lit up	Bulb did not light up
A	1 and 5	✓	
B	1 and 2		✓
C	3 and 4	✓	
D	5 and 3	✓	

Which of the following are correct observations made by Mary?

- A) A and D only
- B) B and C only
- C) A, C and D only
- D) A, B and D only

The diagram below shows an electrical circuit.

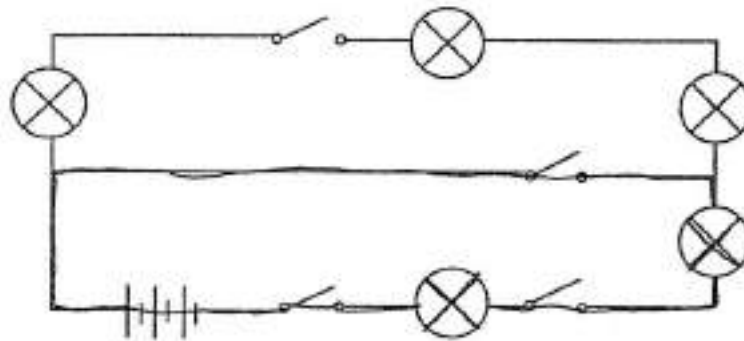

What is the minimum number of switches which need(s) to be closed to light up **only** two bulbs?

- A) One
- B) Two
- C) Three
- D) Four

Adam set up four circuits, P, Q, R and S, using identical batteries, bulbs and wires.

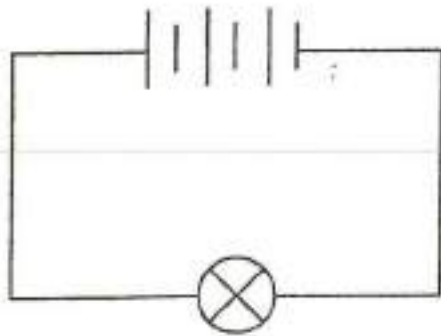

Circuit P

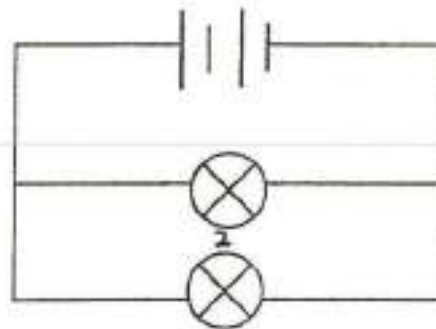

Circuit Q

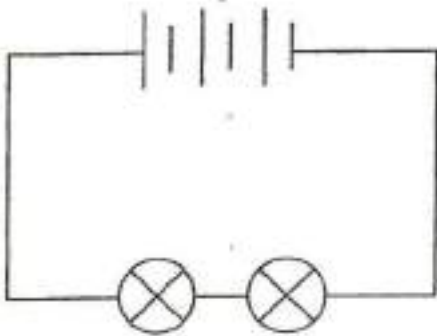

Circuit R

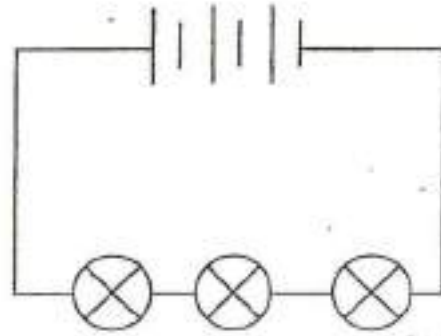

Circuit S

The following statements are made about the circuits above.

- A The bulb in circuit P is the brightest.
- B The bulbs in circuit P and R have the same brightness.
- C The bulbs in circuit Q are brighter than the bulbs in circuit S.
- D The bulbs in circuit S are less bright than the bulbs in circuit R and Q.

Which of the following statements is/are incorrect?

- A) A only
- B) B only
- C) A and B only
- D) A, C and D only

Five bar magnets are placed together and their poles are marked as shown in the diagram below.

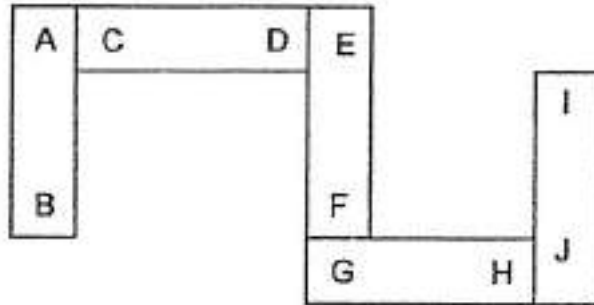

Which of the following diagrams shows the correct interaction when three of the bar magnets from the above set-up are brought close together?

A)

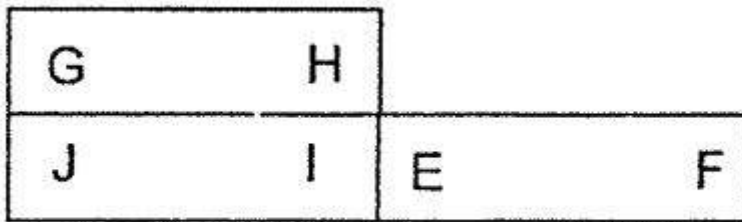

B)

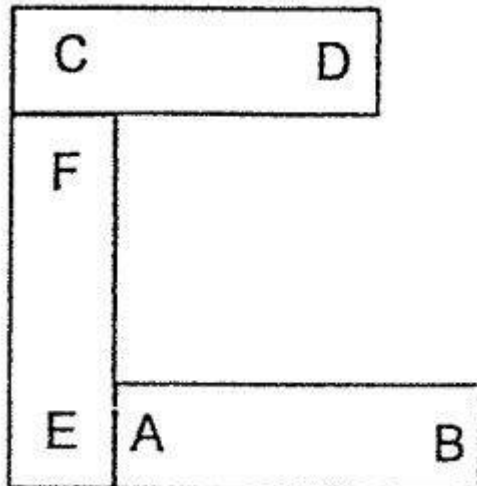

C)

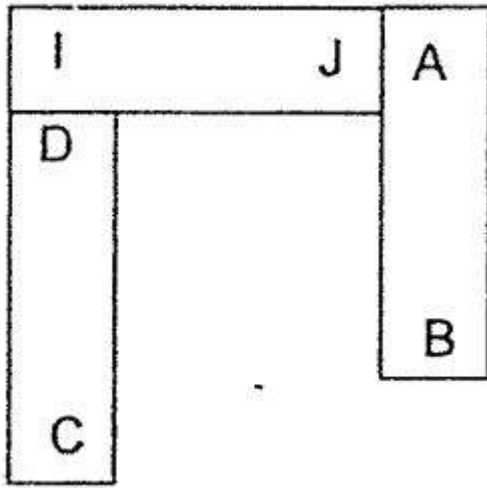

D)

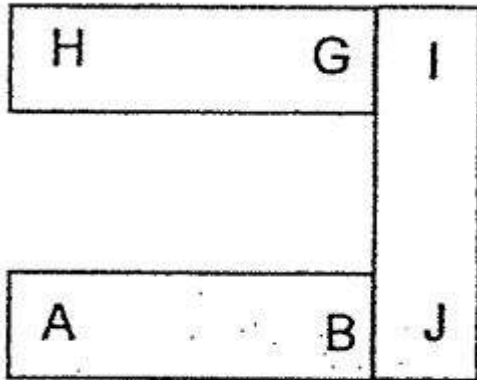

Devi hung four objects, A, B, C and D, on a wooden rod. The diagram shows what she observed.

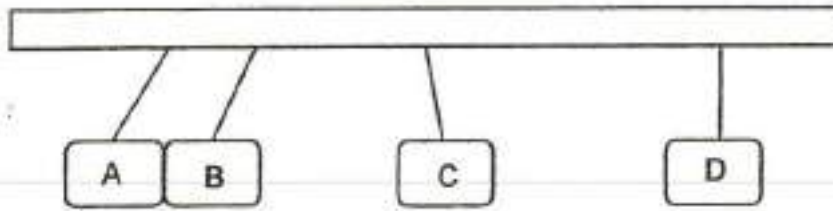

She then exchanged the positions of B and C. The diagram below shows her new observation.

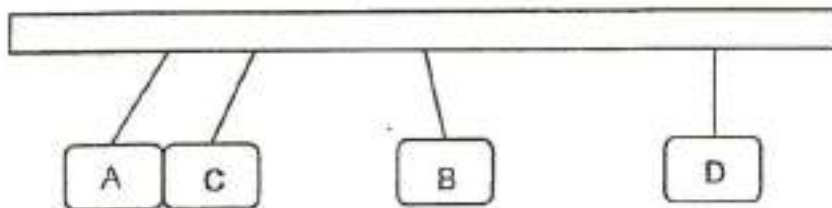

Which of the following correctly describes the objects?

- A)
- | Object A | Object B | Object C | Object D |
|-------------------|-------------------|-------------------|----------|
| magnetic material | magnetic material | magnetic material | magnet |
- B)
- | Object A | Object B | Object C | Object D |
|----------|----------|-------------------|-------------------|
| magnet | magnet | magnetic material | magnetic material |
- C)
- | Object A | Object B | Object C | Object D |
|-------------------|----------|----------|-----------------------|
| magnetic material | magnet | magnet | non magnetic material |
- D)
- | Object A | Object B | Object C | Object D |
|-------------------|-------------------|----------|-----------------------|
| magnetic material | magnetic material | magnet | non magnetic material |

The diagram below shows the parts of the plant and female reproductive systems respectively.

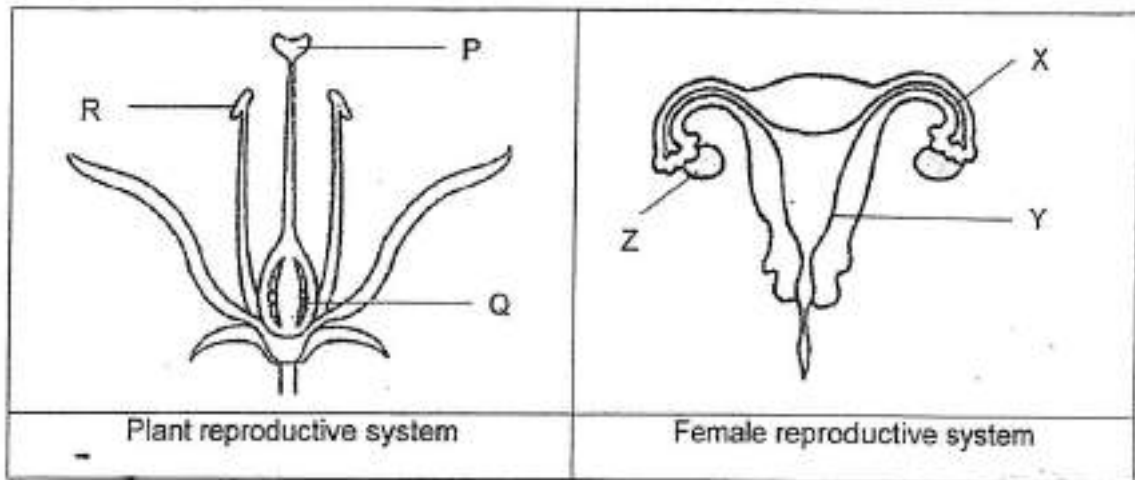

Identify the part labelled Z and state its function. (1 mark)

This question is designed for extended answers that parent/ teacher will have to assign and guide child to attempt after the test has been completed.

Grading: This question type is not graded on this system and will not affect the final score as it was designed in such a way that it requires manual assistance.

The diagram below shows the parts of the plant and female reproductive systems respectively.

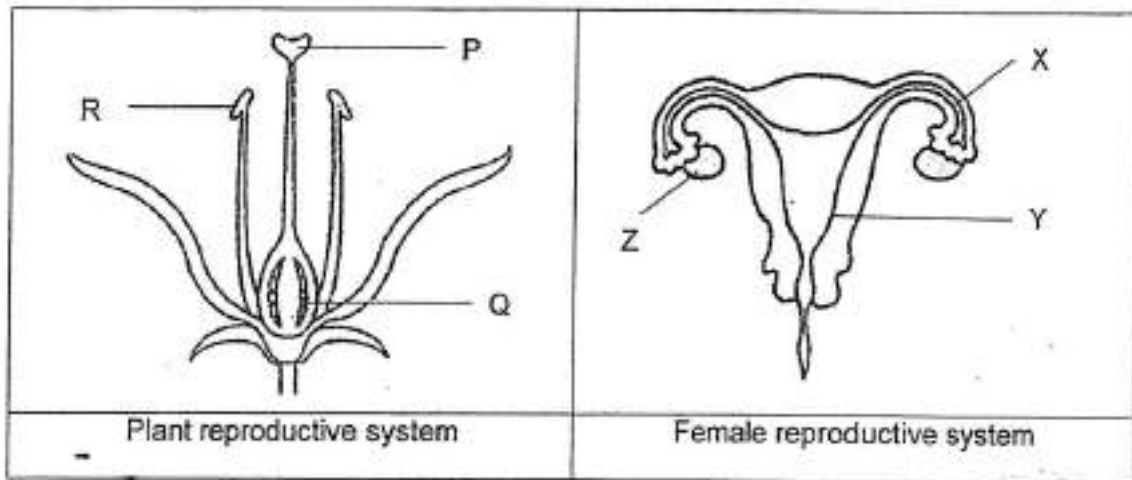

Identify the parts where the male reproductive cell fuses with the female reproductive cell in the plant reproductive system.

Plant reproductive system: _____

The diagram below shows the parts of the plant and female reproductive systems respectively.

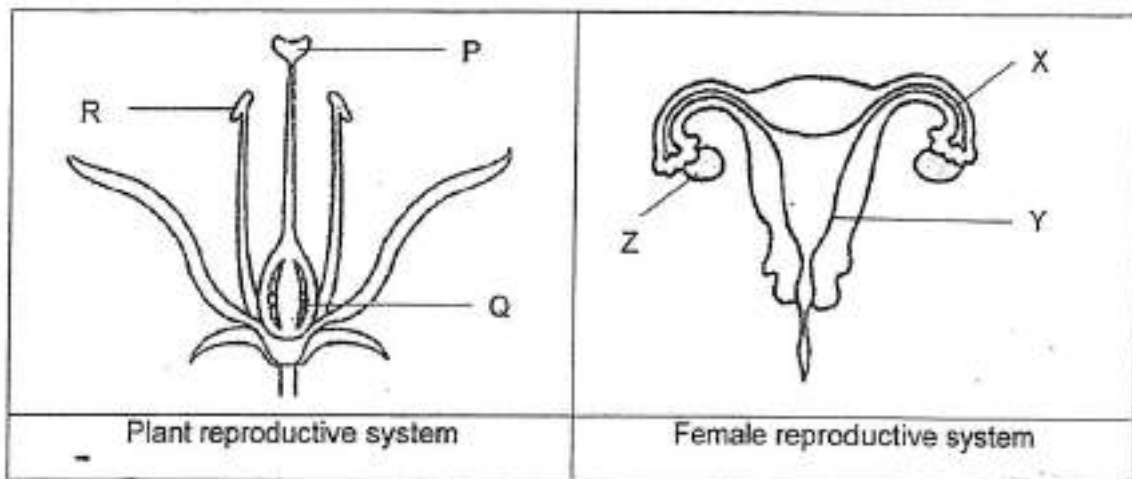

Identify the parts where the male reproductive cell fuses with the female reproductive cell in the female reproductive system.

Female reproductive system: _____

Cheryl carried out an experiment using three different types of seeds. She took some seeds of each type, mixed them together and placed them on a table in front of a fan. After some time, she counted the number of each type of seed in each of the sections marked 1, 2 and 3.

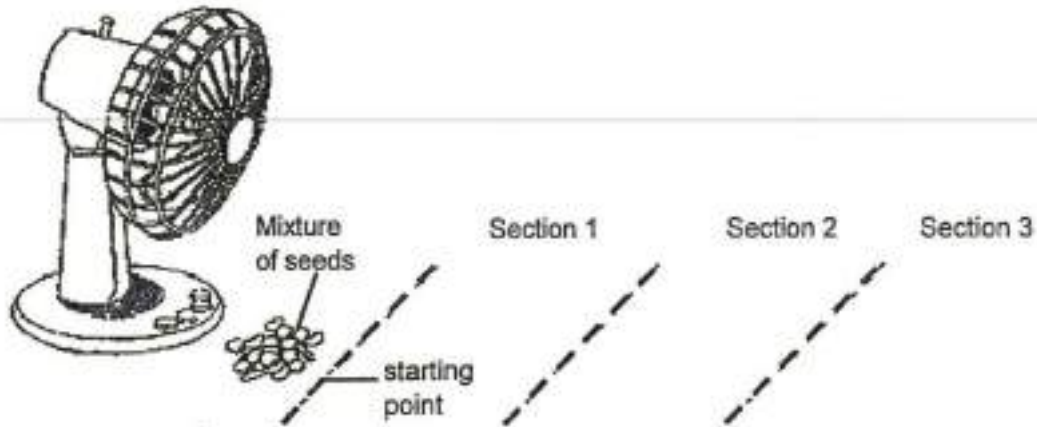

Her results were recorded in the table below.

Type of seeds	Average mass of seed (g)	Number of seeds at starting point	Number of seeds		
			Section 1	Section 2	Section 3
A	1	10	0	1	9
B	1.6	10	2	8	0
C	2.1	10	0	0	0

Based on the results from the experiment, what is the relationship between the mass of the seed and the distance travelled by the seed? (1 mark)

This question is designed for extended answers that parent/ teacher will have to assign and guide child to attempt after the test has been completed.

Grading: This question type is not graded on this system and will not affect the final score as it was designed in such a way that it requires manual assistance.

Cheryl carried out an experiment using three different types of seeds. She took some seeds of each type, mixed them together and placed them on a table in front of a fan. After some time, she counted the number of each type of seed in each of the sections marked 1, 2 and 3.

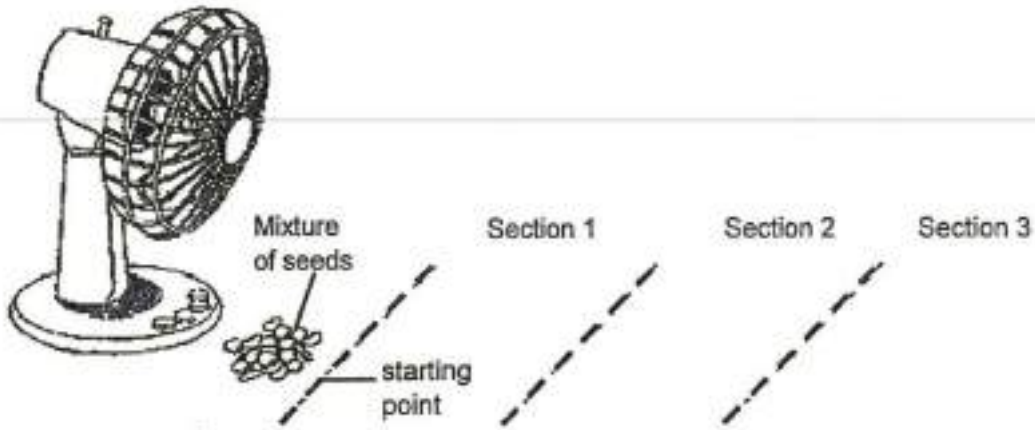

Her results were recorded in the table below.

Type of seeds	Average mass of seed (g)	Number of seeds at starting point	Number of seeds		
			Section 1	Section 2	Section 3
A	1	10	0	1	9
B	1.6	10	2	8	0
C	2.1	10	0	0	0

Identify the type(s) of seeds that is/are more likely dispersed by wind. (1 mark)

Cheryl carried out an experiment using three different types of seeds. She took some seeds of each type, mixed them together and placed them on a table in front of a fan. After some time, she counted the number of each type of seed in each of the sections marked 1, 2 and 3.

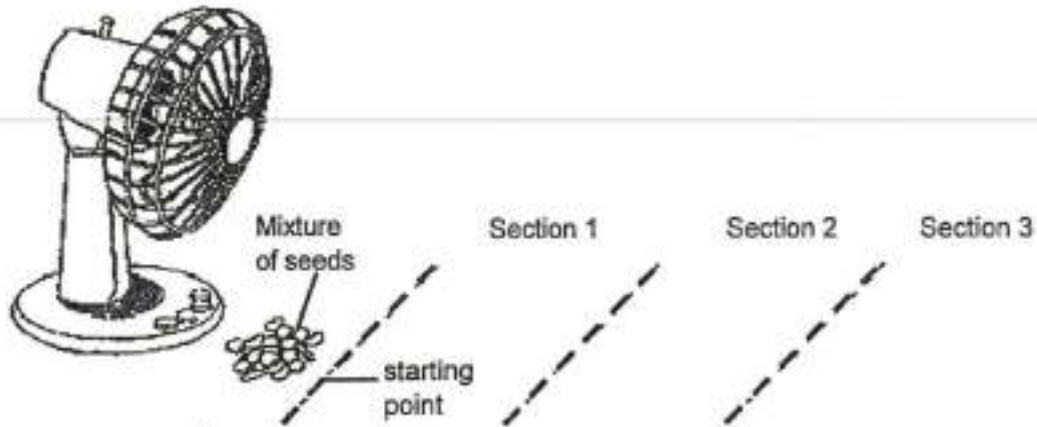

Her results were recorded in the table below.

Type of seeds	Average mass of seed (g)	Number of seeds at starting point	Number of seeds		
			Section 1	Section 2	Section 3
A	1	10	0	1	9
B	1.6	10	2	8	0
C	2.1	10	0	0	0

What should Cheryl do to ensure her results are reliable? (1 mark)

This question is designed for extended answers that parent/ teacher will have to assign and guide child to attempt after the test has been completed.

Grading: This question type is not graded on this system and will not affect the final score as it was designed in such a way that it requires manual assistance.

Sarah prepared four set-ups, A, B, C and D, using identical plants. The pots are filled with the same type of soil to their brims.



A

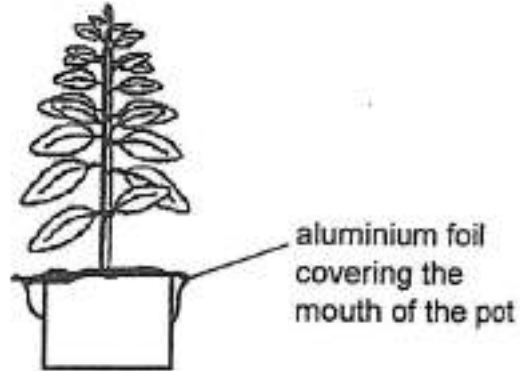

B



C

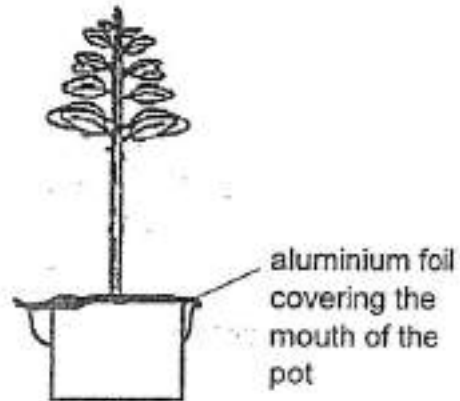

D

Sarah wanted to investigate how the number of leaves affected the rate of water loss by the plant over a week.

Which two set-ups should Sarah use to conduct a fair test?

Sarah prepared four set-ups, A, B, C and D, using identical plants. The pots are filled with the same type of soil to their brims.

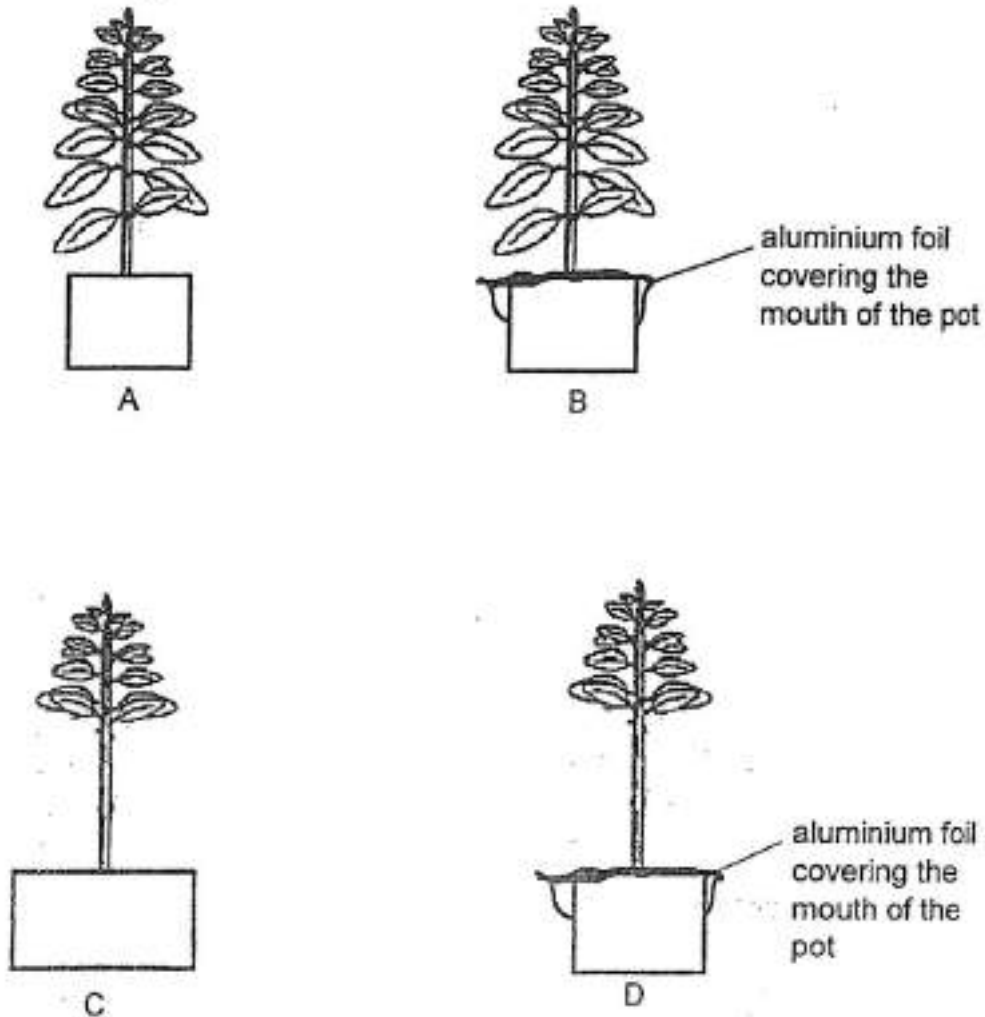

Sarah wanted to investigate how the number of leaves affected the rate of water loss by the plant over a week.

What should Sarah measure in order to find out how the number of leaves affected the rate of water loss by the plant? (1 mark)

This question is designed for extended answers that parent/ teacher will have to assign and guide child to attempt after the test has been completed.

Grading: This question type is not graded on this system and will not affect the final score as it was designed in such a way that it requires manual assistance.

Sarah prepared four set-ups, A, B, C and D, using identical plants. The pots are filled with the same type of soil to their brims.

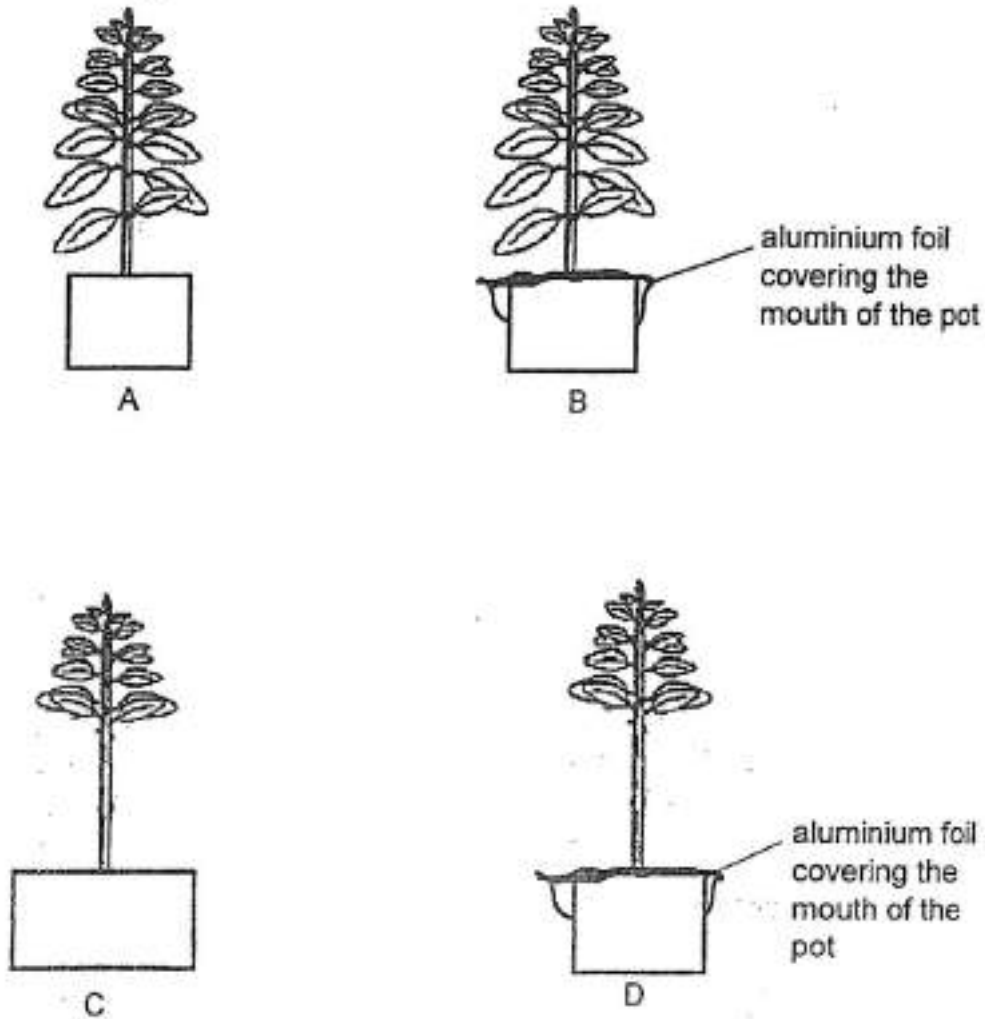

Sarah wanted to investigate how the number of leaves affected the rate of water loss by the plant over a week.

What is the purpose of covering the mouth of the pot with an aluminium foil? (1 mark)

This question is designed for extended answers that parent/ teacher will have to assign and guide child to attempt after the test has been completed.

Grading: This question type is not graded on this system and will not affect the final score as it was designed in such a way that it requires manual assistance.

The diagram below shows a skeletal system.

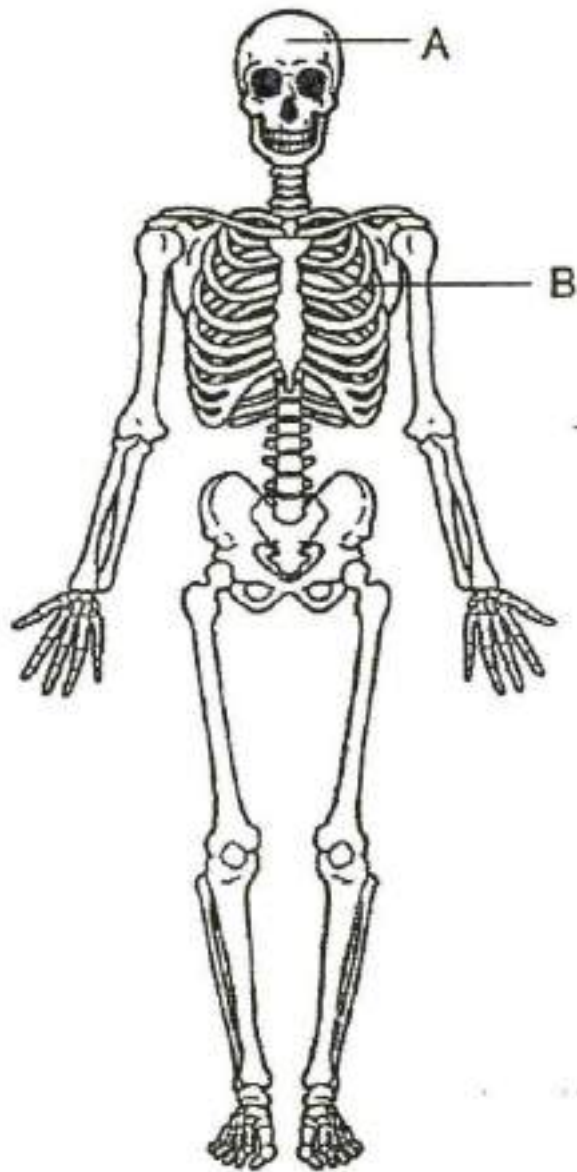

Name the following part in the skeletal system.

Part A: _____

The diagram below shows a skeletal system.

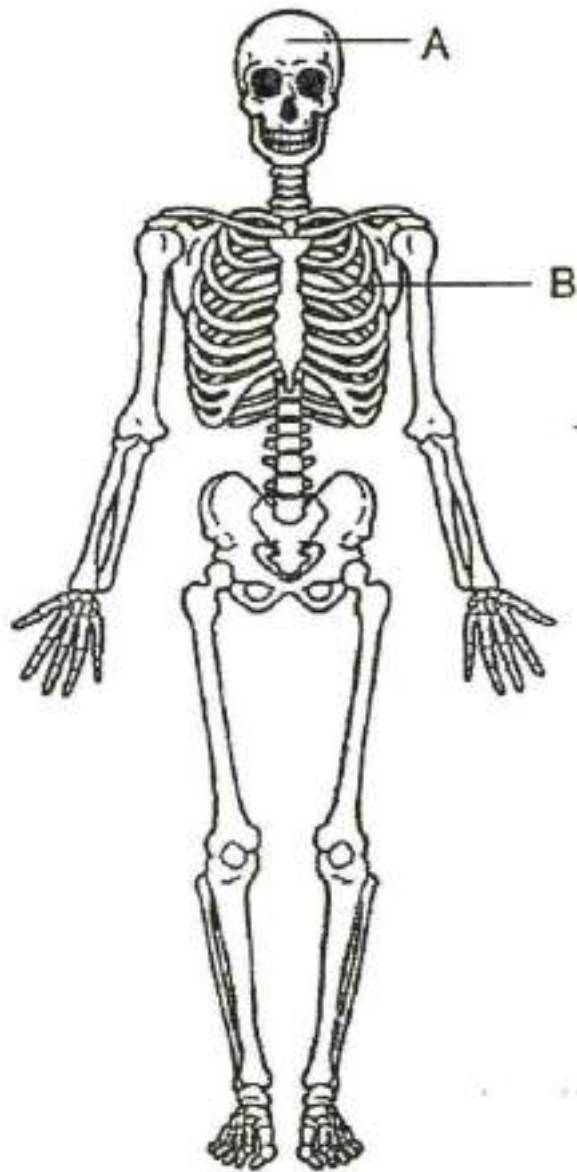

Name the following part in the skeletal system.

Part B: _____

The diagram below shows a skeletal system.

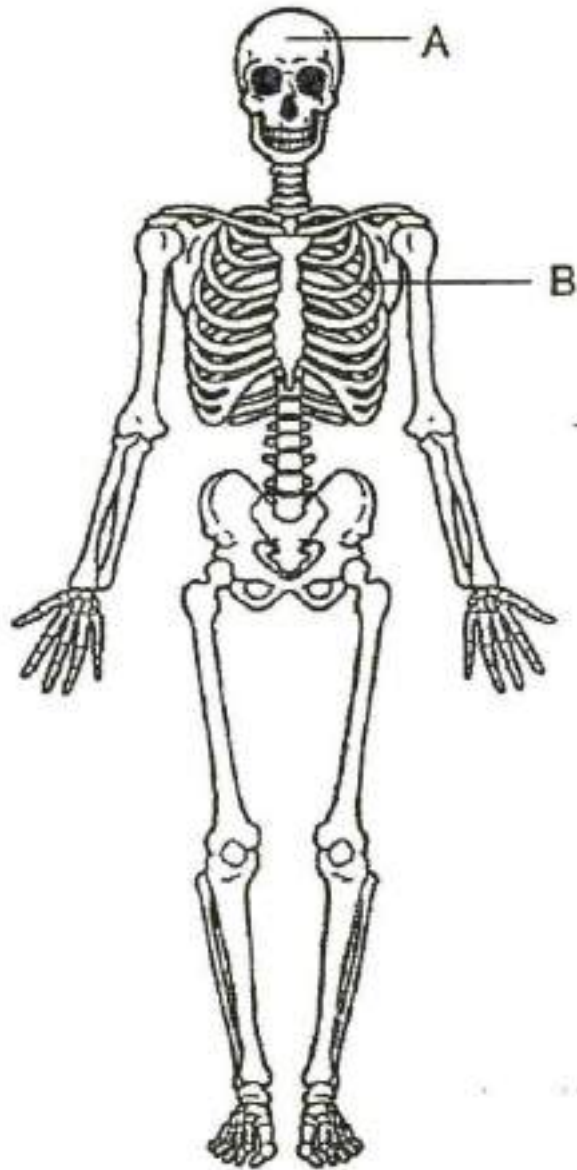

State two functions of the skeletal system. (2 marks)

This question is designed for extended answers that parent/ teacher will have to assign and guide child to attempt after the test has been completed.

Grading: This question type is not graded on this system and will not affect the final score as it was designed in such a way that it requires manual assistance.

Sam was provided with pictures of two different types of cells as shown below.



Cell A

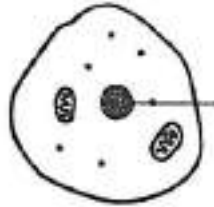

Cell B

Based on the observation above, state two differences that will enable Sam to identify the plant cell. (2 marks)

This question is designed for extended answers that parent/ teacher will have to assign and guide child to attempt after the test has been completed.

Grading: This question type is not graded on this system and will not affect the final score as it was designed in such a way that it requires manual assistance.

The flowchart below shows the respiratory system in both fish and humans. Complete the chart by filling in the boxes below using the correct organs. [2]

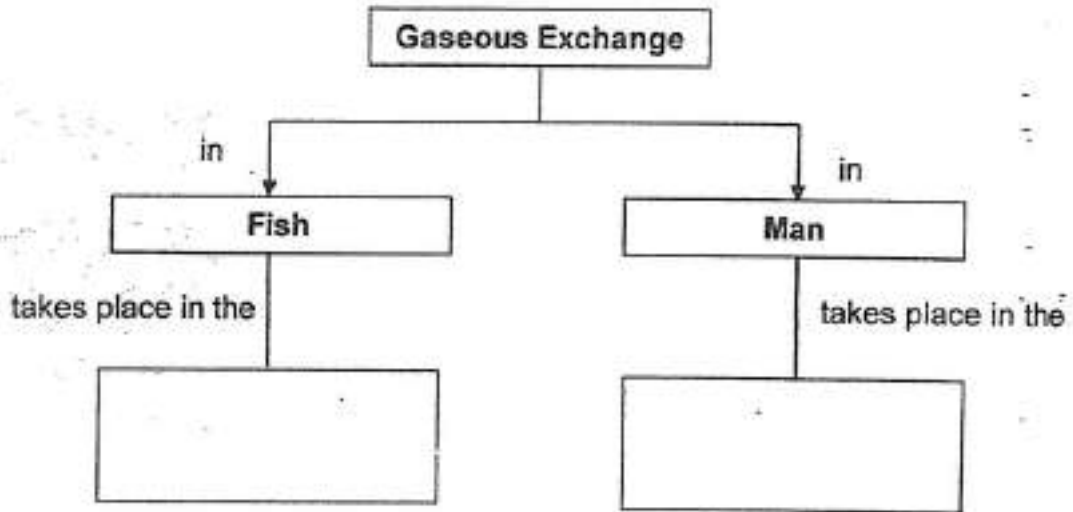

Fish: _____

Man: _____

The graph below show the breathing rate and heart rate of a man who started running.

Breathing rate

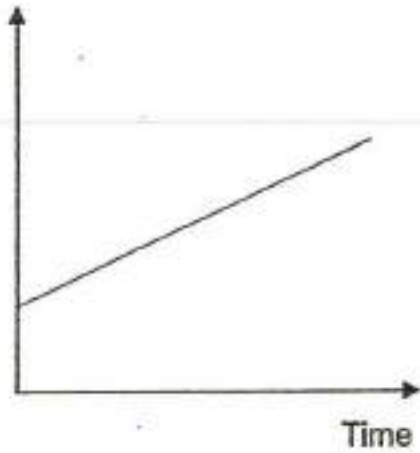

Heart rate

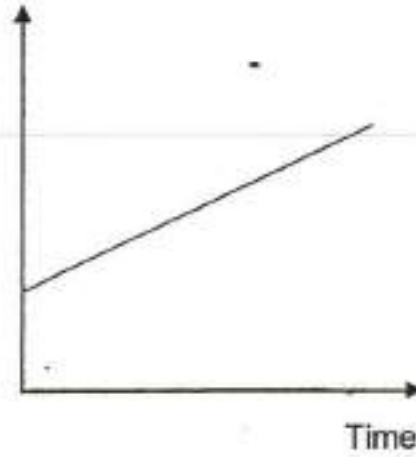

Based on the graphs above, what is the relationship between the breathing rate and heart rate of the man? (1 mark)

This question is designed for extended answers that parent/ teacher will have to assign and guide child to attempt after the test has been completed.

Grading: This question type is not graded on this system and will not affect the final score as it was designed in such a way that it requires manual assistance.

The graph below show the breathing rate and heart rate of a man who started running.

Breathing rate

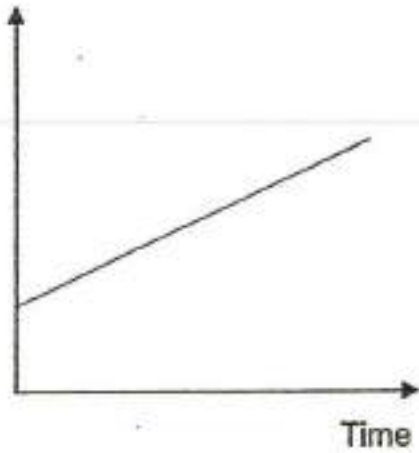

Heart rate

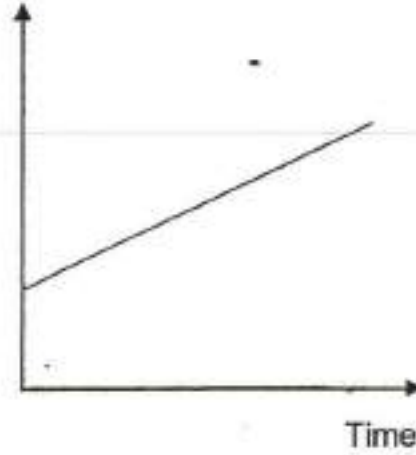

Explain the increase in his heart rate while he is running. (2 marks)

This question is designed for extended answers that parent/ teacher will have to assign and guide child to attempt after the test has been completed.

Grading: This question type is not graded on this system and will not affect the final score as it was designed in such a way that it requires manual assistance.

Look at Diagram A as shown below.

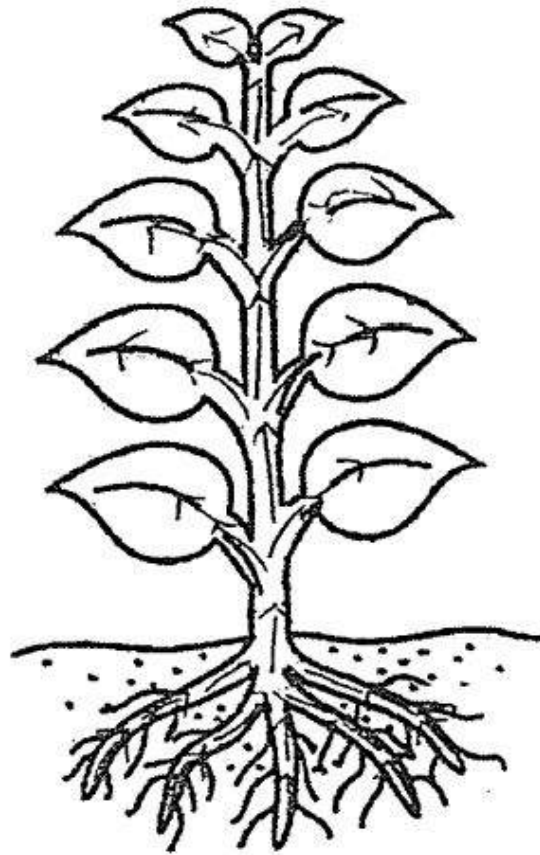

Diagram A

Draw arrows in Diagram A above to show the direction in which water is transported in plant. (1 mark)

This question is designed for extended answers that parent/ teacher will have to assign and guide child to attempt after the test has been completed.

Grading: This question type is not graded on this system and will not affect the final score as it was designed in such a way that it requires manual assistance.

Diagram B below shows the transport system of an animal.

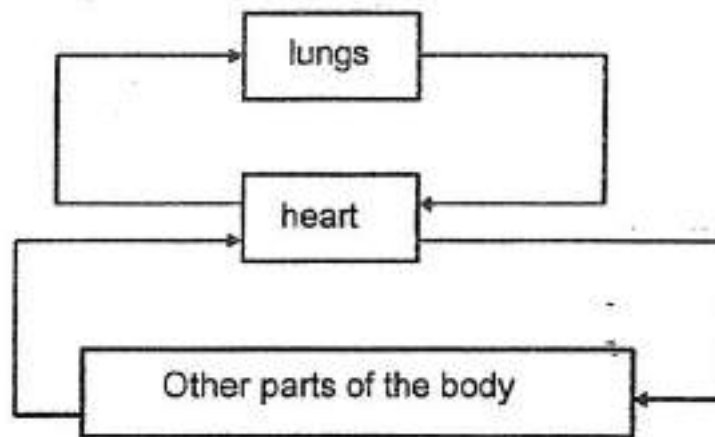

Diagram B

Based on the information in Diagrams A and B, state a difference in the direction between the transport of water in an animal and in a plant. [1]

This question is designed for extended answers that parent/ teacher will have to assign and guide child to attempt after the test has been completed.

Grading: This question type is not graded on this system and will not affect the final score as it was designed in such a way that it requires manual assistance.

Mary conducted the experiment as shown below. A small ring of the outer layer of the stem in set-up B has been removed.

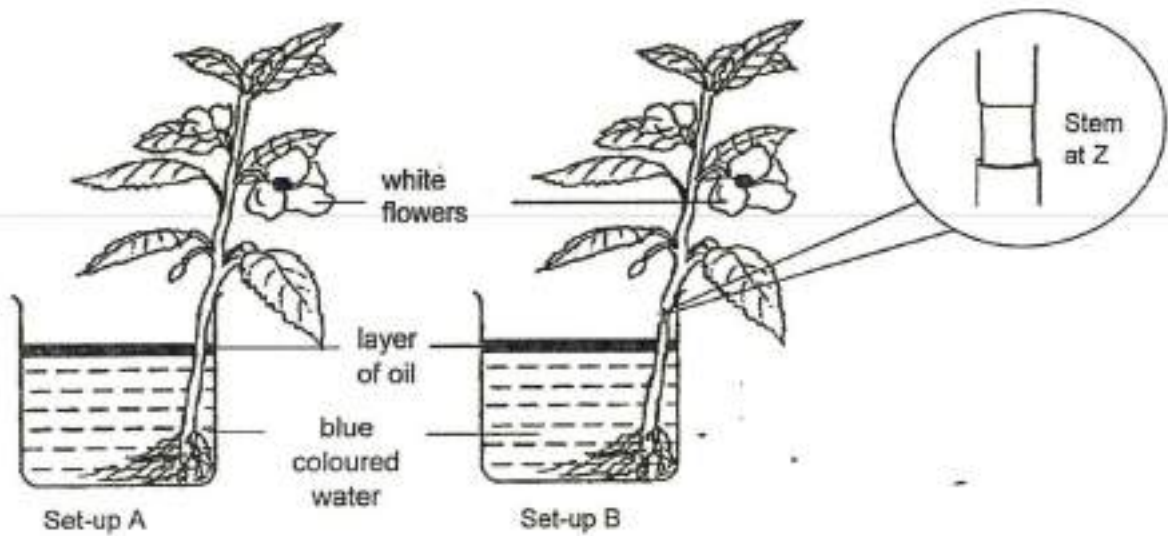

Both set-ups were placed in an open field. After two days, Mary observed swelling only above the ring of the stem at Z in set-up B as shown below.

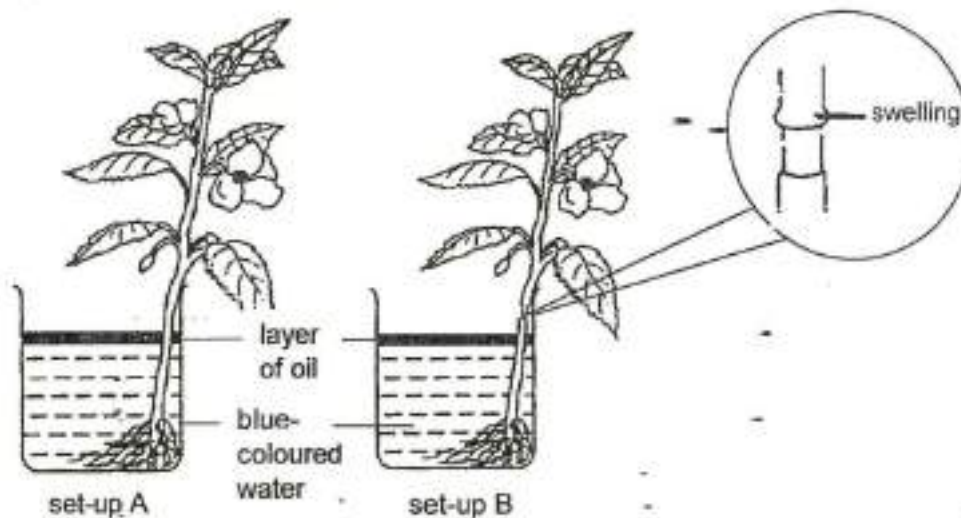

Based on the information above, answer the following questions.

Explain the presence of the swelling above the ring of the stem in set-up B. (1 mark)

This question is designed for extended answers that parent/ teacher will have to assign and guide child to attempt after the test has been completed.

Grading: This question type is not graded on this system and will not affect the final score as it was designed in such a way that it requires manual assistance.

Mary conducted the experiment as shown below. A small ring of the outer layer of the stem in set-up B has been removed.

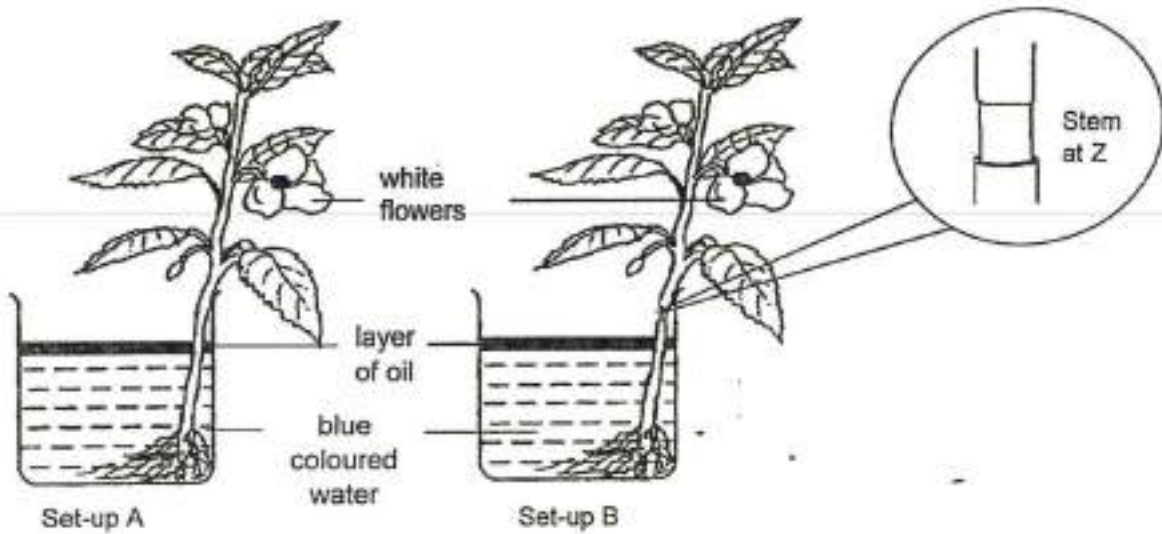

Both set-ups were placed in an open field. After two days, Mary observed swelling only above the ring of the stem at Z in set-up B as shown below.

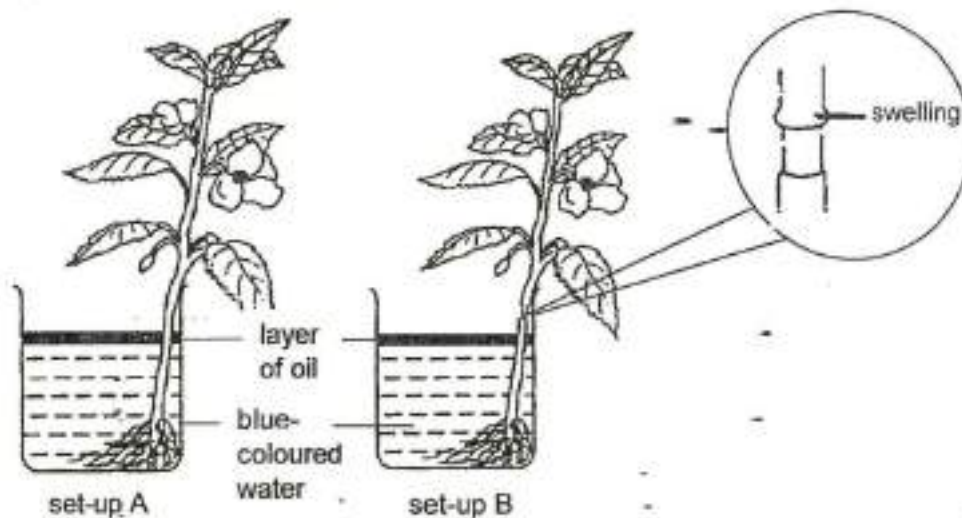

Based on the information above, answer the following questions.

Would Mary observe any changes to the flowers in both set-ups A and B after two days?
 Explain your answer. (2 marks)

This question is designed for extended answers that parent/ teacher will have to assign and guide child to attempt after the test has been completed.

Grading: This question type is not graded on this system and will not affect the final score as it was designed in such a way that it requires manual assistance.

Tiffany wanted to collect some pure water from the seawater. She set up an experiment using the given apparatus. The diagram below shows her observation after fifteen minutes.

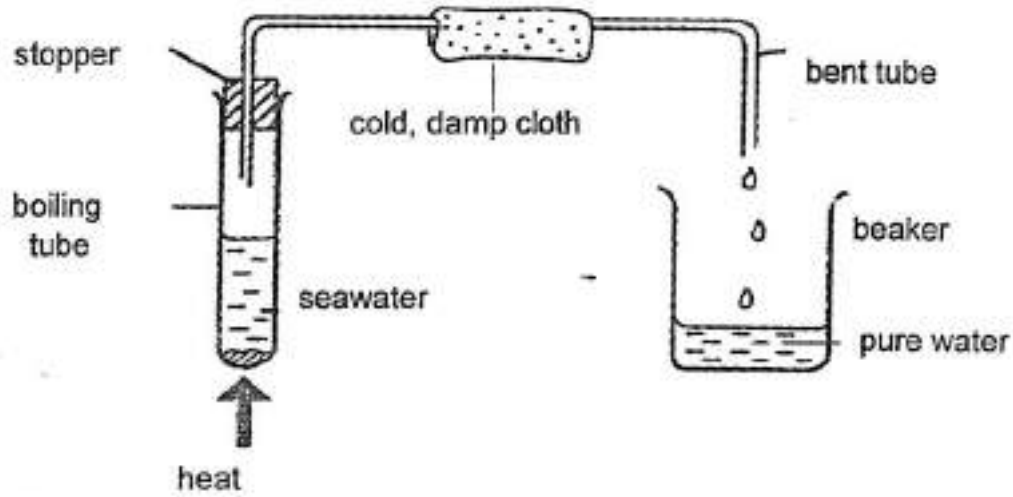

What would be left in the boiling tube after all the water has been boiled completely?

Tiffany wanted to collect some pure water from the seawater. She set up an experiment using the given apparatus. The diagram below shows her observation after fifteen minutes.

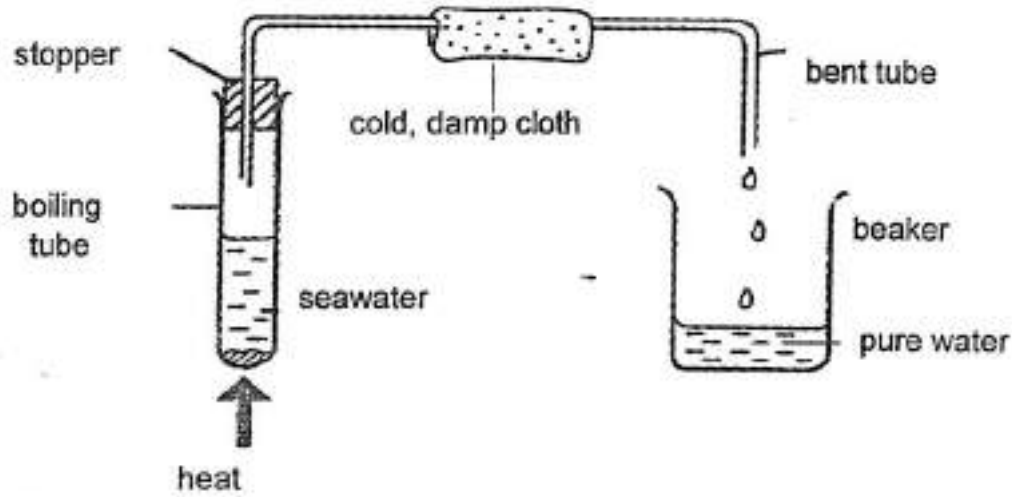

What are the two important processes that must have taken place for pure water to be collected?

Tiffany wanted to collect some pure water from the seawater. She set up an experiment using the given apparatus. The diagram below shows her observation after fifteen minutes.

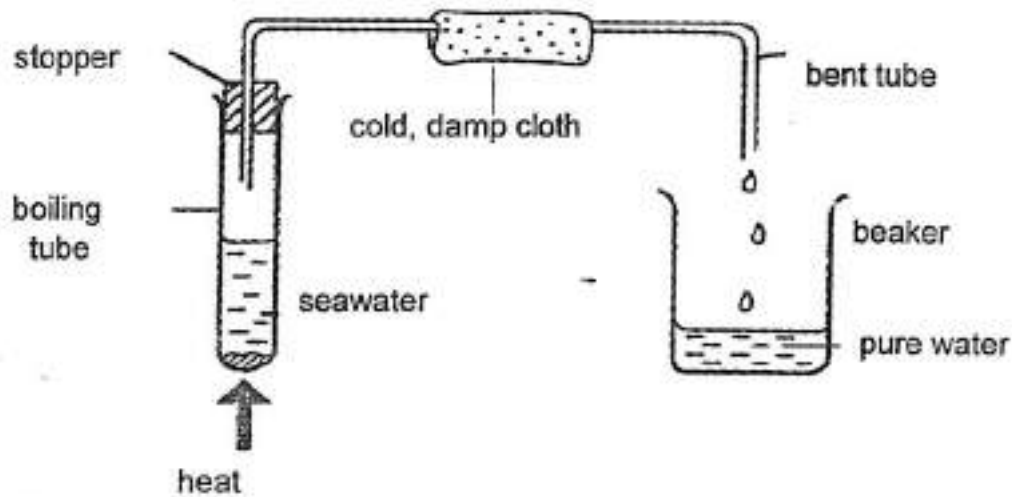

Suggest two ways she could make to the set-up above in order to collect ore water within fifteen minutes of her experiment? (2 marks)

This question is designed for extended answers that parent/ teacher will have to assign and guide child to attempt after the test has been completed.

Grading: This question type is not graded on this system and will not affect the final score as it was designed in such a way that it requires manual assistance.

Fariq used a datalogger to measure the amount of light that passed through different types of materials, D, E and F. The amount of light from the lamp is 1000 lux. He set up the experiment in a dark room as shown in the diagram below.

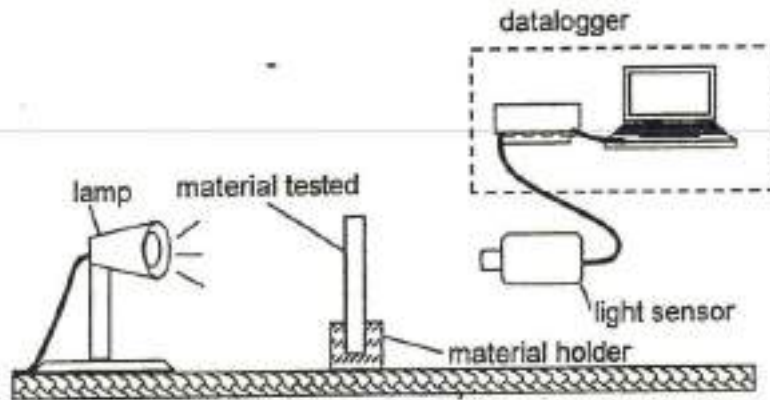

He recorded the results in the table below

Materials	Amount of light detected (lux)
D	750
E	0
F	156

Based on the results, which material is most suitable to be used to make curtains to block out light completely? Give a reason for your answer. (1 mark)

This question is designed for extended answers that parent/ teacher will have to assign and guide child to attempt after the test has been completed.

Grading: This question type is not graded on this system and will not affect the final score as it was designed in such a way that it requires manual assistance.

Fariq used a datalogger to measure the amount of light that passed through different types of materials, D, E and F. The amount of light from the lamp is 1000 lux. He set up the experiment in a dark room as shown in the diagram below.

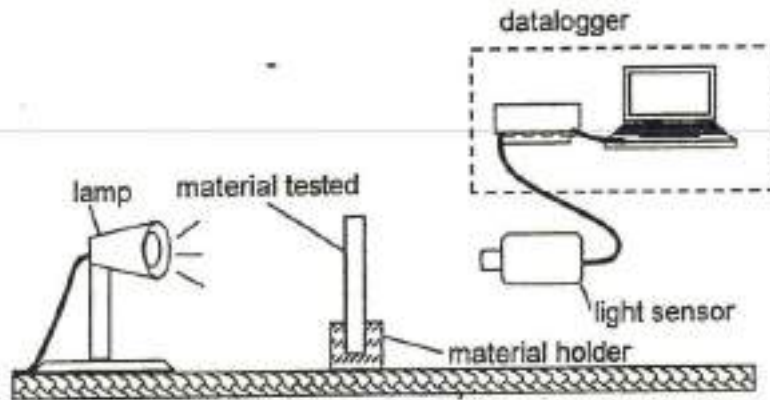

He recorded the results in the table below

Materials	Amount of light detected (lux)
D	750
E	0
F	156

Suggest a reason why the amount of light detected by each material is different. (1 mark)

This question is designed for extended answers that parent/ teacher will have to assign and guide child to attempt after the test has been completed.

Grading: This question type is not graded on this system and will not affect the final score as it was designed in such a way that it requires manual assistance.

Fariq used a datalogger to measure the amount of light that passed through different types of materials, D, E and F. The amount of light from the lamp is 1000 lux. He set up the experiment in a dark room as shown in the diagram below.

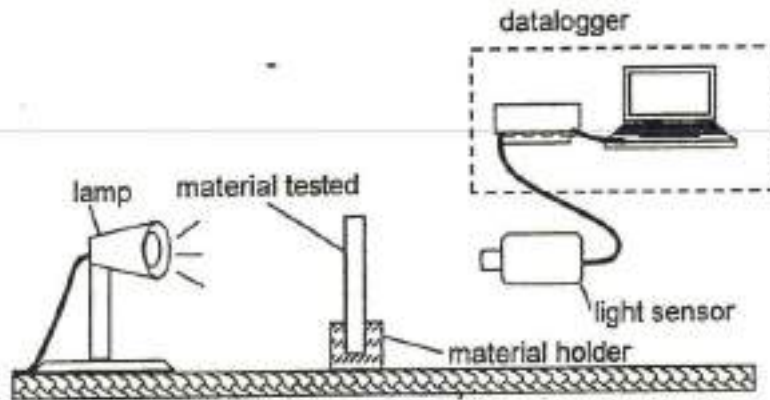

He recorded the results in the table below

Materials	Amount of light detected (lux)
D	750
E	0
F	156

Fariq added a white opaque card in front of the lamp. What would he observe about the amount of light detected by the light sensor for materials D and F? Explain your answer. [2]

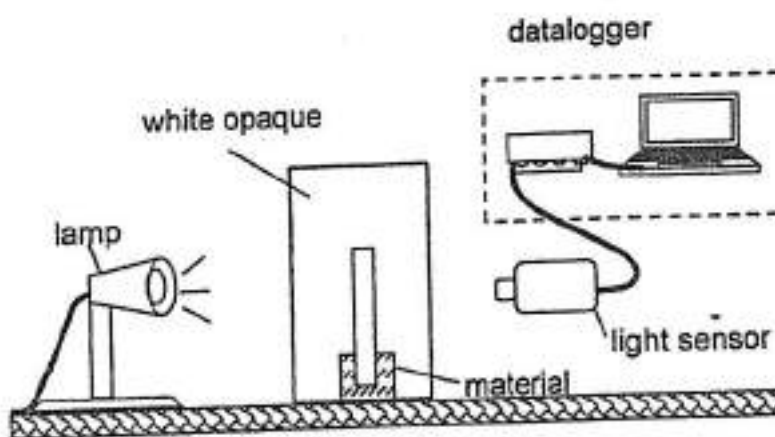

This question is designed for extended answers that parent/ teacher will have to assign and guide child to attempt after the test has been completed.

Grading: This question type is not graded on this system and will not affect the final score as it was designed in such a way that it requires manual assistance.

Joseph set up an electrical circuit as shown in the diagram below.

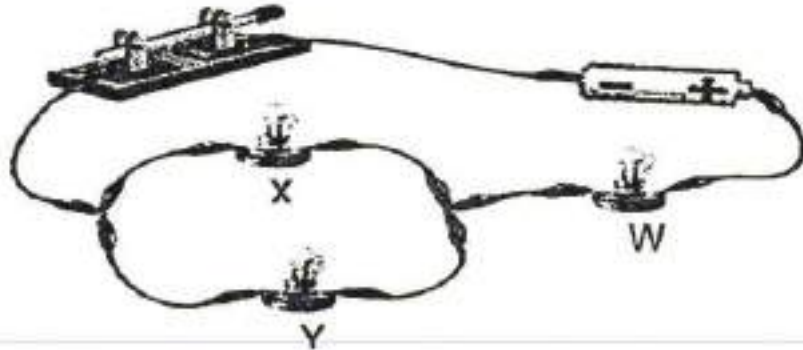

What will Joseph observe if bulb Y fuses? Give a reason for your answer. (1 mark)

This question is designed for extended answers that parent/ teacher will have to assign and guide child to attempt after the test has been completed.

Grading: This question type is not graded on this system and will not affect the final score as it was designed in such a way that it requires manual assistance.

Joseph set up an electrical circuit as shown in the diagram below.

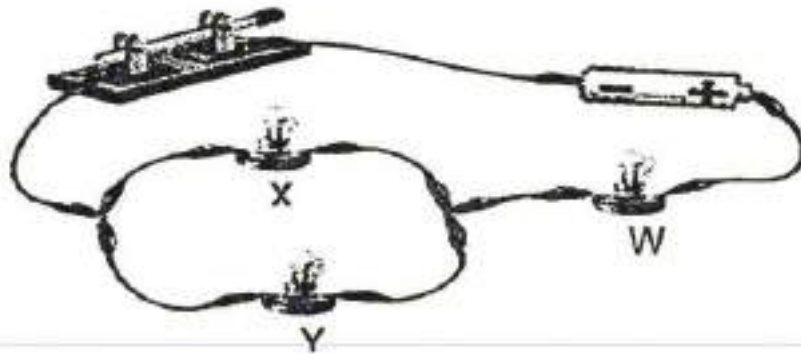

Using all the three bulbs, battery and switch, draw a circuit diagram where the bulbs are rearranged such that they are brighter than the circuit above. (2 marks)

This question is designed for extended answers that parent/ teacher will have to assign and guide child to attempt after the test has been completed.

Grading: This question type is not graded on this system and will not affect the final score as it was designed in such a way that it requires manual assistance.

Joseph set up an electrical circuit as shown in the diagram below.

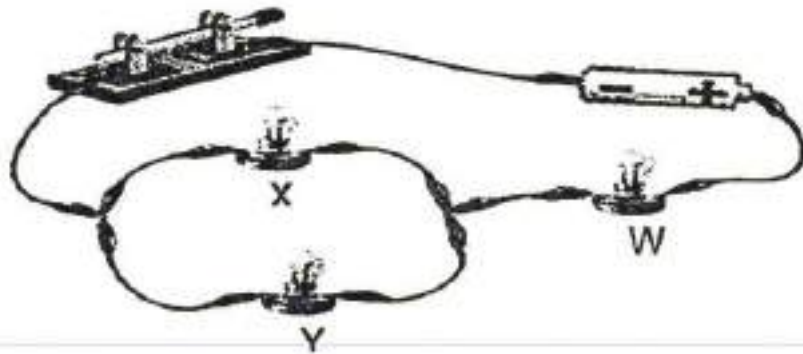

Joseph observed that the three bulbs became dimmer when he added a bulb to the circuit. Label the additional bulb with the letter "B" on the electrical circuit below to indicate where he placed the bulb. [1]

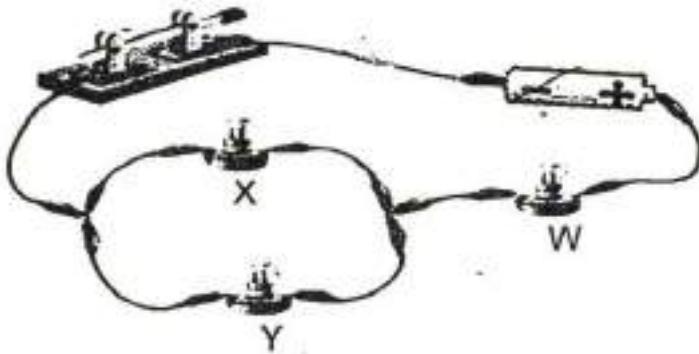

This question is designed for extended answers that parent/ teacher will have to assign and guide child to attempt after the test has been completed.

Grading: This question type is not graded on this system and will not affect the final score as it was designed in such a way that it requires manual assistance.

Question 55 of 56

Primary 5 Science (Term 4) 0 pts

Sally's teacher wrapped three objects A, B and C individually with the ends labelled as shown below.

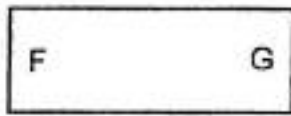

Object A



Object B

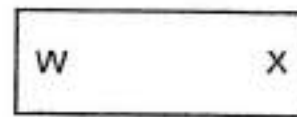

Object C

The three objects are iron rod, copper rod and a magnet.

Sally used a bar magnet to test and found out that Object B is a magnet. What observations should be made to confirm that object B is a magnet? (1 mark)

This question is designed for extended answers that parent/ teacher will have to assign and guide child to attempt after the test has been completed.

Grading: This question type is not graded on this system and will not affect the final score as it was designed in such a way that it requires manual assistance.

Question 56 of 56

Primary 5 Science (Term 4) 0 pts

Sally's teacher wrapped three objects A, B and C individually with the ends labelled as shown below.

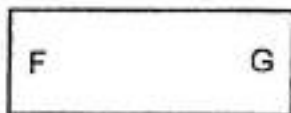

Object A



Object B



Object C

The three objects are iron rod, copper rod and a magnet.

Using only the three objects given above, what can Sally do to find out if object A is an iron rod? (1 mark)

This question is designed for extended answers that parent/ teacher will have to assign and guide child to attempt after the test has been completed.

Grading: This question type is not graded on this system and will not affect the final score as it was designed in such a way that it requires manual assistance.
